



Mining

Wheels





OTR Engineered Solutions (OTR)

is your global partner for high-quality off-the-road tires, wheels, assemblies, and accessories. We are proud to supply end-user customers, dealers, and original equipment manufacturers with engineered solutions to meet and exceed common — and uncommon — challenges in such core markets as Agriculture, Construction, Forestry, Industrial, Lawn & Garden, Material Handling, Mining, Powersports, and Specialty Vehicles. But our success is much more than the products we offer. We're a multinational enterprise with more than 1,400 employees throughout 32 facilities worldwide dedicated to supporting you with a full range of high-level services to help you Roll More™.

Mining

OTR's product lineup for vehicles used in surface and underground mining is the result of many years of experience, innovations, and a hands-on approach that ensures our products get the job done. Whether you are focused on vehicle productivity, utilization, safety, or value, OTR's team will help you find the right solution.

Features and Notes

Standard OTR Wheels

- Designs and sizes compliant with industry standards; compatible as replacements for all wheel brands used in market.
- Full penetration welds with 100% phased array ultrasonic (PA) inspection to assure weld integrity and long-life.
- OTR wheels produced in ISO 9001 registered facilities.

Heavy-Duty Wheels

- Fully-machined lock ring grooves for precise fitment and stress relief.
- Fully-machined O-ring grooves for optimal sealing and air pressure retention.
- Heavy-duty back sections for extreme loads and duty cycle.
- Notched rim bases; outdoor driver pocket options available.
- Special alloy steel option for wheels used in high-pressure applications. Consult with your OTR salesperson for more information.
- Valve hole size/placement options for select rim bases.

Large Diameter Wheels (49"-63")

- HSLA-grade steel used for critical components.
- Seamless forged gutters and fully-machined sections.
- Integrated bead seat Sur-Loc design to prevent inflation when using incorrect mounting ring.

6- & 7-Piece Quick-Change Wheels

- Designs enable demount and vertical mounting without having to remove inside dual tire.
- Compatible with popular fitments and replacements of other brands used in market.

Underground Mining Wheels

- Seamless forged sections for all critical components.
- Fully machined flanges, gutter, and back sections ensure mating component parts have exact fitment needed with evenly distributed stress for reduced wear.

Additional Notes

- NHS referenced in tire size: Not for Highway Service.
- Sur-Loc side rings available for 25"-29" diameter wheels.



Table of Contents

Guide Information

Quick Reference Guide.....	6
Tire to Rim Conversion Table.....	8
Safety.....	9

3-Piece Rim Assemblies

25" 3-Piece Rim Assemblies, T, TD	10
25" 3-Piece Rim Assemblies, Heavy-Duty	11

5-Piece Rim Assemblies

25" 5-Piece Rim Assemblies, STG, STN	12
25" 5-Piece Rim Assemblies, HTG, HTN, HTM	13
29" 5-Piece Rim Assemblies, HTHG, HTHM.....	14
33"-45" 5-Piece Rim Assemblies, RTEL, RHTHM	15
33"-49" 5-Piece Rim Assemblies, RW.....	16
35"-49" 5-Piece Rim Assemblies, MRW.....	17
51"-57" 5-Piece Rim Assemblies, Standard	18
51"-57" 5-Piece Rim Assemblies, Heavy-Duty.....	19
63" 5-Piece Rim Assemblies, Standard	20
63" 5-Piece Rim Assemblies, Heavy-Duty	21
63" 5-Piece Rim Assemblies, Heavy-Duty Tapered	22
TLS HD 5-Piece Rim Assemblies	23
Standard 5-Piece Rim Assemblies.....	24

6-Piece Rim Assemblies

TLS HD 6-Piece Rim Assemblies	26
-------------------------------------	----

7-Piece Rim Assemblies

TLS HD 7-Piece Rim Assemblies	27
Standard 7-Piece Rim Assemblies.....	28

Components for Rim/Wheel Assemblies

25" Side Rings for 3-Piece Rims/Wheels	30
25" Lock Rings for 3-Piece Rims/Wheels.....	31
25" & 29" Flanges for 5-Piece Rims/Wheels.....	32
25" & 29" Lock Rings for 5-Piece Rims/Wheels.....	33
25" & 29" Bead Seat Bands for 5-Piece Rims/Wheels.....	34
33"-49" Flanges for 5-Piece Rims/Wheels	35
33"-49" Lock Rings for 5-Piece Rims/Wheels	36
33"-49" Bead Seat Bands for 5-Piece Rims/Wheels	37
51"-57" Flanges for 5-Piece Rims/Wheels	38
51"-57" Lock Rings for 5-Piece Rims/Wheels	39
51"-57" Bead Seat Bands With Sur-Loc for Standard 5-Piece Rims/Wheels.....	39
51"-57" Bead Seat Bands for Heavy-Duty 5-Piece Rims/Wheels.....	40
57" Bead Seat Bands With Sur-Loc for Heavy-Duty 5-Piece Rims/Wheels.....	40
63" Flanges for Standard 5-Piece Rims/Wheels	41
63" Flanges for Heavy-Duty 5-Piece Rims/Wheels	41
63" Flanges for Heavy-Duty Tapered 5-Piece Rims/Wheels	42
63" Lock Rings for Standard 5-Piece Rims/Wheels	42
63" (45°) Lock Rings for Heavy-Duty Tapered 5-Piece Rims/Wheels	43
63" (35°) Lock Rings for Heavy-Duty Tapered 5-Piece Rims/Wheels	43
63" Bead Seat Bands for Standard 5-Piece Rims/Wheels	44
63" Bead Seat Bands for Heavy-Duty 5-Piece Rims/Wheels	44
63" Bead Seat Bands for Heavy-Duty Tapered 5-Piece Rims/Wheels	45
Driver Keys.....	46

References

Stamped Part Number Locations.....	47
Examples of Wheel Offsets Inset & Zeraset.....	48
Examples of Wheel Offsets Outset, Wheel Disc Styles & Wheel Disc Types.....	49
Rim Terminology.....	50

Underground Mining

51

Services

Wheel Inspection and Certification.....	52
---	----

Information & Disclaimers

53



Guide Information

Quick Reference Guide

OTR produces and supplies standard and custom wheels for surface mining applications, ranging in diameter from 25" to 63" in 3-, 5-, and 7-piece configurations, as well as underground mining wheels from 15" to 24" in 3- and 4-piece configurations. Wheel options and types are referenced below:

Configuration	Type	Rim Size	Page
Surface Mining Applications			
25" 3-PIECE	T, HD	25-10.00/1.5, 25-12.00/1.3, 25-14.00/1.5, 25-17.00/1.7	10
25" 3-PIECE	HD	25-19.50/2.5, 25-22.00/3.0, 25-25.00/3.5	11
25" 5-PIECE	STG, STN	25-11.25/2.0, 25-13.00/2.5, 25-15.00/3.0	12
25" 5-PIECE	HTG, HTN, HTM	25-17.00/2.0, 25-17.00/3.5, 25-19.50/2.5, 25-22.00/3.0, 25-25.00/3.5	13
29" 5-PIECE	HTHG, HTHM	29-17.00/3.5, 29-22.00/3.0, 29-24.00/3.0, 29-24.00/3.5, 29.00-25.00/3.5	14
33"-45" 5-PIECE	RTEL, RHTHM	33-28.00/3.5, 33-28.00/4.0, 33-32.00/4.5, 35-27.00/3.5, 35-31.00/4.0, 39-28.00/4.0, 39-32.00/4.0, 39-32.00/4.5, 45-36.00/4.5	15
33"-49" 5-PIECE	RW	33-13.00/2.5, 35-15.00/3.0, 35-17.00/3.5, 49-17.00/3.5, 49-19.50/4.0	16
35"-49" 5-PIECE	MRW	35-15.00/3.0, 49-17.00/3.5, 49-19.50/4.0	17
51"-57" 5-PIECE	STD	51-22.00/4.5, 51-24.00/5.0, 51-26.00/5.0, 51-32.00/4.5, 51-40.00/4.5, 57-27.00/6.0, 57-29.00/6.0	18
51"-57" 5-PIECE	HD	51-22.00/4.5, 51-24.00/5.0, 51-26.00/5.0, 51-32.00/4.5, 51-40.00/4.5, 57-27.00/6.0, 57-29.00/6.0	19
63" 5-PIECE	STD	63-36.00/5.0	20
63" 5-PIECE	HD	63-36.00/5.0, 63-41.00/5.0, 63-44.00/5.0	21
63" 5-PIECE	HDT	63-36.00/5.0, 63-41.00/5.0, 63-44.00/5.0	22
57"-63" 5-, 6-, & 7-PIECE	TLS HD, STD	57-29.00/6.0, 63-36.00/5.0, 63-41.00/5.0, 63-44.00/5.0	23-28
Underground Mining Applications			
15"-24" 4-PIECE	HD	15-11, 20-8.50, 20-11.00, 24-11.00	

Wheel Type Legend

Type	Definition
T	<i>Standard rim assembly with valve hole, general-duty.</i>
TD	<i>Standard demountable rim with valve hole for hub interface.</i>
HD	<i>Heavy-duty design.</i>
STG	<i>Standard rim assembly.</i>
STD	<i>Standard-duty rim assembly.</i>
STN	<i>Standard rim assembly with notch.</i>
HDT	<i>Heavy-duty rim assembly, tapered.</i>
HTG	<i>Heavy-duty rim assembly, no driver pocket.</i>
HTN	<i>Heavy-duty rim assembly, no driver pocket with notch.</i>
HTM	<i>Heavy-duty rim assembly with driver pocket system.</i>
HTHG	<i>Heavy-duty rim assembly, no driver pocket.</i>
HTHM	<i>Heavy-duty rim with driver pocket.</i>
RTEL	<i>Standard "R" style rim with driver pocket.</i>
RTHM	<i>Heavy-duty "R" style rim with driver pocket.</i>
RW	<i>Standard "RW" style rim with reinforced back, bead seat, and lip for easy demounting.</i>
MRW	<i>Standard "MRW" style rim with machined gutter and "W" style lock ring.</i>
TLS	<i>Tapered locking system for heavy-duty wheels with a double-gutter (DG) design for 7-piece assemblies (for easy demounting and quick changeover), and 6-piece units also featuring an integrated lock ring.</i>



Tire to Rim Conversion Table

The following table shows common tire and approved rim sizes for each tire according to the “Tire and Rim Association.” Due to variances in load, speed, inflation pressure, and type of service, you should always consult with your tire and wheel distributor and/or manufacturer. The use of incorrect flanges can lead to premature tire wear and failures.

Tire Size	Rim Size
14.00-20	20-10.00
14.00-21, 16.00-21	21-10.00
10.00-24, 11.00-24, 12.00-24	24-8.00TG
13.00-24, 14.00-24	24-8.00TG
14.00-24	24-10.00TG
16.00-24	24-10.00VA
13.00-25, 14.00-25	25-10.00
15.50-25	25-12.00
16.00-25	25-11.25
17.50-25	25-14.00
18.00-25	25-13.00
20.50-25	25-17.00
21.00-25	25-15.00
23.50-25	25-19.50
26.50-25	25-22.00
29.50-25	25-25.00
24.00-29	29-17.00
26.50-29	29-22.00
30/65-29	29-24.00
29.50-29	29-25.00
33.25-29	29-27.00
18.00-33	33-13.00
27.00-33	33-22.00
33.50-33	33-28.00
35/65-33	33-28.00
37.50-33	33-32.00
21.00-35	35-15.00
24.00-35	35-17.00

Tire Size	Rim Size
33.25-35	35-27.00
37.25-35	35-31.00
33.50-39	39-28.00
37.50-39, 40.5/75-39, 40/65-39	39-32.00
41.25/70-39	39-32.00
45/65-39	39-36.00
45/65-45	45-36.00
24.00-49	49-17.00
27.00-49	49-19.50
30.00-51	51-22.00
33.00-51	51-24.00
36.00-51	51-26.00
37.50-51	51-32.00
50/65-51	51-40.00
50.00-51	51-40.00
37.00-57	57-27.00
40.00-57, 46/90 R57	57-29.00
48/95-57, 44/80 R57, 50/90 R57	57-32.00
40/80 R57, 50/80 R57	57-34.00
49.5-57, 49.5/85-57, 50/80-57, 44/95 R57, 52/80-57	57-36.00
53.5/85-57, 55/80-57, 55.5/80-57	57-44.00
58/85-57, 53.5-57	57-47.00
65/65-57	57-52.00
70/70-57	57-60.00
53/80 R63	63-36.00
55/80 R63	63-41.00
58/80 R63, 59/80 R63	63-44.00

SAFETY FIRST



WARNING

The task of servicing tires and wheels is potentially dangerous and should be performed by trained personnel only, using the correct tools and procedures. Failure to heed this warning could lead to serious injury or death. We urge those involved in the servicing of tires and wheels to read the U.S. Department of Labor and Occupation Safety and Health Administration (OSHA) document 29 CFR part 1910.177 entitled, Servicing of Single Piece and Multi Piece Rim Wheels.

NOTE: Single piece rims have the rims made out of a single piece of material and multi-piece rims have a loose flange or flange and lock ring.

Wear protective gloves, footwear, safety glasses, and head gear when servicing tire and wheel components.

Further references explaining safety procedures can be found in literature published by the Rubber Manufacturer's Association, Washington D.C., the National Tire Dealers and Retreaders Association, Washington D.C., and the National Wheel and Rim Association, Jacksonville, FL.

Rim Assemblies

25" T, TD 3-PIECE RIM ASSEMBLIES

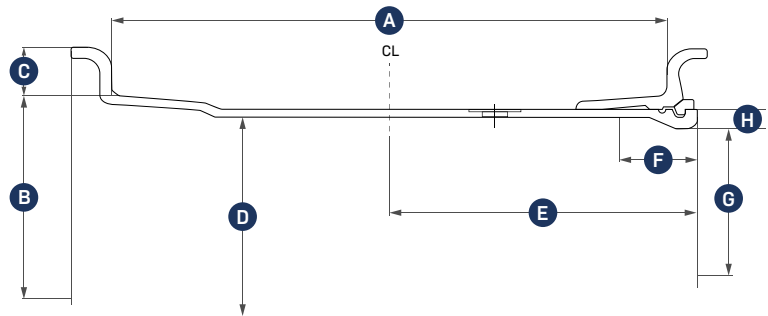

Rim Size	Dimensions							
	A	B	C	D	E	F	G	H
DIAMETER-WIDTH / FLANGE HEIGHT	IN (MM)	IN (MM)	IN (MM)	IN (MM)	IN (MM)	IN (MM)	IN (MM)	IN (MM)
25-10.00 / 1.5	10 (254.0)	25 (635.0)	1.5 (38.1)	23.392 (594.2)	6.031 (153.2)	2.031 (51.6)	22.5 (571.5)	0.719 (18.3)
25-12.00 / 1.3	12 (304.8)	25 (635.0)	1.3 (33.0)	23.392 (594.2)	6.89 (175.0)	1.898 (48.2)	22.5 (571.5)	0.719 (18.3)
25-14.00 / 1.5	14 (355.6)	25 (635.0)	1.5 (38.1)	23.392 (594.2)	8.031 (204.0)	2.031 (51.6)	22.5 (571.5)	0.719 (18.3)
25-17.00 / 1.7	17 (431.8)	25 (635.0)	1.7 (43.2)	23.392 (594.2)	9.531 (242.1)	2.031 (51.6)	22.5 (571.5)	0.719 (18.3)

Rim Size	Fits Tire Size	Assembly Weight	Part Numbers			
			RIM BASE	SIDE RING	LOCK RING	O-RING
DIAMETER-WIDTH / FLANGE HEIGHT		LBS (KG)				
25-10.00 / 1.5	14.00-25 NHS	149.2 (67.7)	B1025T B1025TD	F1025T F1025T	LR25T LR25T	OR25T OR25T
25-12.00 / 1.3	15.5-25	135.8 (61.6)	B12025T	F25TU1.3	LR25T	OR25T
25-14.00 / 1.5	17.5-25	175.9 (79.8)	B14025T	F1025T	LR25T	OR25T
25-17.00 / 1.7	20.5-25	188.2 (85.4)	B17025TGF	F25TG	LR25T	OR25T

25" HEAVY-DUTY

3-PIECE RIM ASSEMBLIES

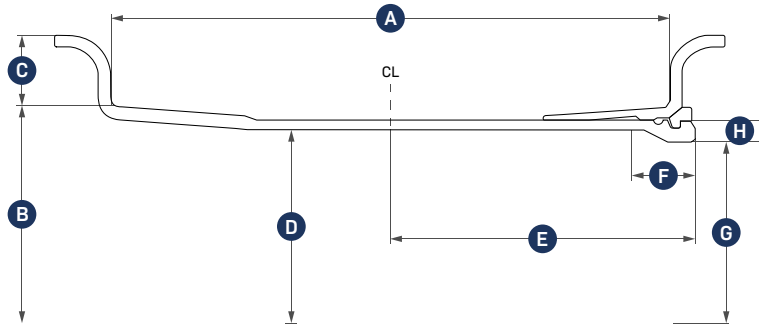

Rim Size	Dimensions							
	A	B	C	D	E	F	G	H
DIAMETER-WIDTH / FLANGE HEIGHT	IN (MM)	IN (MM)	IN (MM)	IN (MM)	IN (MM)	IN (MM)	IN (MM)	IN (MM)
25-19.5 / 2.5	19.5 (495.3)	25 (635.0)	2.5 (63.5)	23.38 (593.9)	11.69 (296.9)	2.03 (51.6)	21.5 (546.1)	1.06 (26.9)
25-22.00 / 3.0	22 (558.8)	25 (635.0)	3 (76.2)	23.38 (593.9)	12.94 (328.7)	2.03 (51.6)	21.5 (546.1)	1.06 (26.9)
25-25.00 / 3.5	25 (635.0)	25 (635.0)	3.5 (88.9)	23.38 (593.9)	14.31 (363.5)	2.03 (51.6)	21.5 (546.1)	1.06 (26.9)

Rim Size	Fits Tire Size	Assembly Weight	Part Numbers				
			LBS (KG)	RIM BASE	FLANGE	LOCK RING	O-RING
DIAMETER-WIDTH / FLANGE HEIGHT							
25-19.5 / 2.5	23.50-25	384 (174.2)	ER5200A	ELFC0325/2.5	LR255TM	OR325T	
25-22.00 / 3.0	26.50-25	473 (214.5)	ER5300A	ELFC0325/3.0	LR255TM	OR325T	
25-25.00 / 3.5	29.50-25	537.5 (243.8)	ER5400A	ELFC0325/3.5	LR255TM	OR325T	



25" STG, STN

5-PIECE RIM ASSEMBLIES

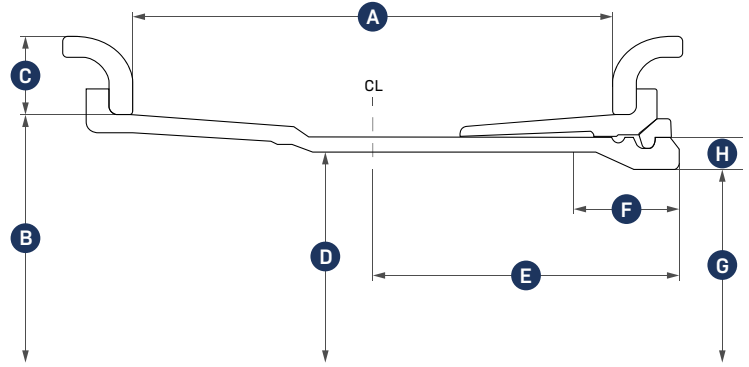

Rim Size	Dimensions							
	A	B	C	D	E	F	G	H
DIAMETER-WIDTH / FLANGE HEIGHT	IN (MM)	IN (MM)	IN (MM)	IN (MM)	IN (MM)	IN (MM)	IN (MM)	IN (MM)
25-11.25 / 2.0	11.25 (285.8)	25 (635.0)	2 (50.8)	22.625 (574.7)	7.312 (185.7)	3.255 (82.7)	21.5 (546.1)	1.06 (26.9)
25-13.00 / 2.5	13 (330.2)	25 (635.0)	2.5 (63.5)	22.625 (574.7)	8.312 (211.1)	3.255 (82.7)	21.5 (546.1)	1.06 (26.9)
25-15.00 / 3.0	15 (381.0)	25 (635.0)	3 (76.2)	22.625 (574.7)	9.312 (236.5)	3.255 (82.7)	21.5 (546.1)	1.06 (26.9)

Rim Size	Fits Tire Size	Assembly Weight	Part Numbers				
			RIM BASE	BEAD SEAT	SIDE FLANGE	LOCK RING	O-RING
DIAMETER-WIDTH / FLANGE HEIGHT		LBS (KG)					
25-11.25 / 2.0	16.00-25	294.2 (133.4)	B1125STG	BB25STG	S2025	LR255TM	OR325T
25-11.25 / 2.0	16.00-25	294.6 (133.6)	B1125STN	BB25STN	S2025	LR255TN	OR325T
25-13.00 / 2.5	18.00-25	353.1 (160.2)	B1325STG	BB25STG	S2525	LR255TM	OR325T
25-13.00 / 2.5	18.00-25	353.9 (160.5)	B1325STN	BB25STN	S2525	LR255TN	OR325T
25-15.00 / 3.0	21.00-25	408.1 (185.1)	B1525STG	BB25STG	S3025	LR255TM	OR325T
25-15.00 / 3.0	21.00-25	408.5 (185.3)	B1525STN	BB25STN	S3025	LR255TN	OR325T

25" HTG, HTN, HTM

5-PIECE RIM ASSEMBLIES

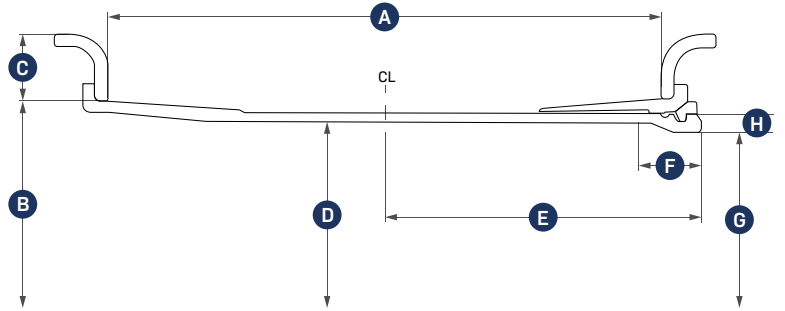

Rim Size	Dimensions							
	A	B	C	D	E	F	G	H
DIAMETER-WIDTH / FLANGE HEIGHT	IN (MM)	IN (MM)	IN (MM)	IN (MM)	IN (MM)	IN (MM)	IN (MM)	IN (MM)
25-17.00 / 3.5	17 (431.8)	25 (635.0)	3.5 (88.9)	22.625 (574.7)	10.312 (261.9)	3.255 (82.7)	21.5 (546.1)	1.06 (26.9)
25-17.00 / 2.0	17 (431.8)	25 (635.0)	2 (50.8)	22.625 (574.7)	10.312 (261.9)	3.255 (82.7)	21.5 (546.1)	1.06 (26.9)
25-19.50 / 2.5	19.5 (495.3)	25 (635.0)	2.5 (63.5)	22.625 (574.7)	11.687 (296.8)	3.255 (82.7)	21.5 (546.1)	1.06 (26.9)
25-19.50 / 2.5	19.5 (495.3)	25 (635.0)	2.5 (63.5)	22.625 (574.7)	11.687 (296.8)	3.255 (82.7)	21.5 (546.1)	1.06 (26.9)
25-22.00 / 3.0	22 (558.8)	25 (635.0)	3 (76.2)	22.625 (574.7)	12.937 (328.6)	3.255 (82.7)	21.5 (546.1)	1.06 (26.9)
25-22.00 / 3.0	22 (558.8)	25 (635.0)	3 (76.2)	22.625 (574.7)	12.937 (328.6)	3.255 (82.7)	21.5 (546.1)	1.06 (26.9)
25-25.00 / 3.5	25 (635.0)	25 (635.0)	3.5 (88.9)	22.625 (574.7)	14.312 (363.5)	3.255 (82.7)	21.5 (546.1)	1.06 (26.9)

Rim Size	Fits Tire Size	Assembly Weight	Part Numbers				
			LBS (KG)	RIM BASE	BEAD SEAT	SIDE FLANGE	LOCK RING
DIAMETER-WIDTH / FLANGE HEIGHT							
25-17.00 / 3.5	24.00-25	380 (9,652.0)	B1725HTG	BB25HTG	S3525	LR255TM	OR325T
25-17.00 / 2.0	20.5-25	380 (9,652.0)	B1725HTN	BB25STN	S2025	LR255TN	OR325T
25-17.00 / 2.0	20.5-25	381.9 (9,700.3)	B1725HTM	BB25STM	S2025	LR255TM	OR325T
25-19.50 / 2.5	23.5-25	446.7 (11,346.2)	B1925HTG	BB25STG	S2525	LR255TM	OR325T
25-19.50 / 2.5	23.5-25	443.9 (11,275.1)	B1925HTN	BB25STN	S2525	LR255TN	OR325T
25-19.50 / 2.5	23.5-25	445.8 (11,323.3)	B1925HTM	BB25STM	S2525	LR255TM	OR325T
25-22.00 / 3.0	26.5-25	499 (12,674.6)	B2225HTG	BB25HTG	S3025	LR255TM	OR325T
25-22.00 / 3.0	26.5-25	504.7 (12,819.4)	B2225HTN	BB25HTN	S3025	LR255TN	OR325T
25-22.00 / 3.0	26.5-25	515.9 (13,103.9)	B2225HTM	BB25HTM	S3025	LR255TM	OR325T
25-25.00 / 3.5	29.5-25	551.4 (14,005.6)	B2525HTG	BB25HTG	S3525	LR255TM	OR325T
25-25.00 / 3.5	29.5-25	553.7 (14,064.0)	B2525HTN	BB25HTN	S3525	LR255TN	OR325T
25-25.00 / 3.5	29.5-25	564.4 (14,335.8)	B2525HTM	BB25HTM	S3525	LR255TM	OR325T

29" HTHG, HTHM

5-PIECE RIM ASSEMBLIES

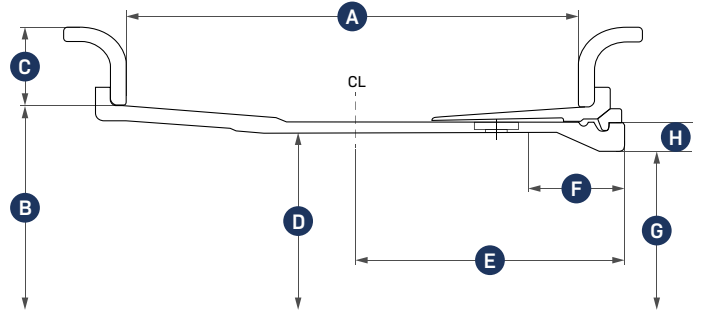

Rim Size	Dimensions							
	A	B	C	D	E	F	G	H
DIAMETER-WIDTH / FLANGE HEIGHT	IN (MM)	IN (MM)	IN (MM)	IN (MM)	IN (MM)	IN (MM)	IN (MM)	IN (MM)
29-17.00 / 3.5	17 (431.8)	29 (736.6)	3.5 (88.9)	26.625 (676.3)	10.312 (261.9)	3.567 (90.6)	24.875 (631.8)	1.38 (35.1)
29-22.00 / 3.0	22 (558.8)	29 (736.6)	3 (76.2)	26.625 (676.3)	12.937 (328.6)	3.567 (90.6)	24.875 (631.8)	1.38 (35.1)
29-24.00 / 3.0	24 (609.6)	29 (736.6)	3 (76.2)	26.625 (676.3)	13.984 (355.2)	3.567 (90.6)	24.875 (631.8)	1.38 (35.1)
29-24.00 / 3.5	24 (609.6)	29 (736.6)	3.5 (88.9)	26.625 (676.3)	13.984 (355.2)	3.567 (90.6)	24.875 (631.8)	1.38 (35.1)
29-25.00 / 3.5	25 (635.0)	29 (736.6)	3.5 (88.9)	26.625 (676.3)	14.312 (363.5)	3.567 (90.6)	24.875 (631.8)	1.38 (35.1)

Rim Size	Fits Tire Size	Assembly Weight	Part Numbers				
			RIM BASE	BEAD SEAT	SIDE FLANGE	LOCK RING	O-RING
DIAMETER-WIDTH / FLANGE HEIGHT		LBS (KG)					
29-17.00 / 3.5	24.00-29	561.7 (14,267.2)	B1729HTHM	BB29HTM	S3529	LR295TM	OR329T
29-22.00 / 3.0	26.5-29	600.2 (15,245.1)	B2229HTHM	BB29HTM	S3029	LR295TM	OR329T
29-24.00 / 3.0	30/65-29	636.1 (16,156.9)	B2429HTHM	BB29HTM	S3029	LR295TM	OR329T
29-24.00 / 3.5	26.5-29	650.3 (16,517.6)	B2429HTHM	BB29HTM	S3529	LR295TM	OR329T
29-25.00 / 3.5	29.5-29	660.6 (16,779.2)	B2529HTHM	BB29HTM	S3529	LR295TM	OR329T

Mining Rim Assemblies

33"-45" RTEL, RHTHM

5-PIECE RIM ASSEMBLIES

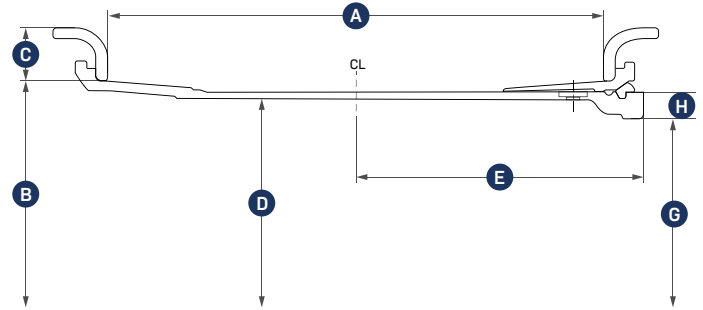

Rim Size	Dimensions							
	A	B	C	D	E	F	G	H
DIAMETER-WIDTH / FLANGE HEIGHT	IN (MM)	IN (MM)	IN (MM)	IN (MM)	IN (MM)	IN (MM)	IN (MM)	IN (MM)
33-22.00 / 4.0	22 (558.8)	33 (838.2)	4.5 (114.3)	30.625 (777.9)	13.187 (334.9)	N/A	27.938 (709.6)	1.84 (46.7)
33-28.00 / 3.5	28 (711.2)	33 (838.2)	3.5 (88.9)	30.625 (777.9)	16.187 (411.1)	N/A	27.938 (709.6)	1.84 (46.7)
33-28.00 / 4.0	28 (711.2)	33 (838.2)	4 (101.6)	30.625 (777.9)	16.187 (411.1)	N/A	27.938 (709.6)	1.84 (46.7)
33-32.00 / 4.5	32 (812.8)	33 (838.2)	4.5 (114.3)	30.625 (777.9)	18.281 (464.3)	N/A	27.938 (709.6)	1.84 (46.7)
35-27.00 / 3.5	27 (685.8)	35 (889.0)	3.5 (88.9)	32.625 (828.7)	15.562 (395.3)	N/A	29.938 (760.4)	1.84 (46.7)
35-31.00 / 4.0	31 (787.4)	35 (889.0)	4 (101.6)	32.625 (828.7)	17.781 (451.6)	N/A	29.938 (760.4)	1.84 (46.7)
39-28.00 / 4.0	28 (711.2)	39 (990.6)	4 (101.6)	36.625 (930.3)	16.187 (411.1)	N/A	33.938 (862.0)	1.84 (46.7)
39-32.00 / 4.0	32 (812.8)	39 (990.6)	4 (101.6)	36.625 (930.3)	18.281 (464.3)	N/A	33.938 (862.0)	1.84 (46.7)
39-32.00 / 4.5	32 (812.8)	39 (990.6)	4.5 (114.3)	36.625 (930.3)	18.281 (464.3)	N/A	33.938 (862.0)	1.84 (46.7)
45-36.00 / 4.5	36 (914.4)	45 (1,143.0)	4.5 (114.3)	42.625 (1,082.7)	20.281 (515.1)	N/A	39.938 (1,014.4)	1.84 (46.7)

Rim Size	Fits Tire Size	Assembly Weight	Part Numbers				
			RIM BASE	BEAD SEAT	SIDE FLANGE	LOCK RING	O-RING
DIAMETER-WIDTH / FLANGE HEIGHT		LBS (KG)					
33-22.00 / 4.0	27.00-33	860.2 (21,849.1)	B2233RTEL	BB33RTL	S4033	LR335TM	OR333T
33-28.00 / 3.5	35/65-33	885.8 (22,499.3)	B2833RHTHM	BB33RTL	S3533	LR335TM	OR333T
33-28.00 / 4.0	33.5-33	905.6 (23,002.2)	B2833 RHTHM	BB33RTL	S4033	LR335TM	OR333T
33-32.00 / 4.5	37.5-33	995.1 (25,275.5)	B3233RTEL	BB33RTL	S4533	LR335TM	OR333T
35-27.00 / 3.5	33.25-35	869.7 (22,090.4)	B2735RTEL	BB35RTL	S3535	LR355TM	OR335T
35-31.00 / 4.0	37.25-35	1,018.1 (25,859.7)	B3135RTEL	BB35RTL	S4035	LR355TM	OR335T
39-28.00 / 4.0	33.5-39	1,080.3 (27,439.6)	B2839RTEL	BB39RTL	S4039	LR395TM	OR339T
39-32.00 / 4.0	40/65-39	1,163.4 (29,550.4)	B3239RTEL	BB39RTL	S4039	LR395TM	OR339T
39-32.00 / 4.5	41.25/70-39 37.5-39	1,184 (30,073.6)	B3239RTEL	BB39RTL	S4539	LR395TM	OR339T
45-36.00 / 4.5	45/65-45	1,442.2 (36,631.9)	B3645RTEL	BB45RT91	S4545	LR455TM	OR345T



33"-49" RW

5-PIECE RIM ASSEMBLIES

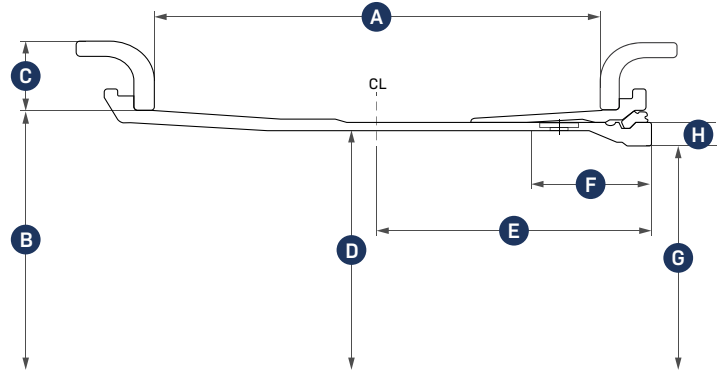

Rim Size	Dimensions							
	A	B	C	D	E	F	G	H
DIAMETER-WIDTH / FLANGE HEIGHT	IN (MM)	IN (MM)	IN (MM)	IN (MM)	IN (MM)	IN (MM)	IN (MM)	IN (MM)
33-13.00 / 2.5	13 (330.2)	33 (838.2)	2.5 (63.5)	30.625 (777.9)	8.093 (205.6)	3.567 (90.6)	28.875 (733.4)	1.38 (35.1)
35-15.00 / 3.0	15 (381.0)	35 (889.0)	3 (76.2)	32.625 (828.7)	9.312 (236.5)	3.567 (90.6)	30.875 (784.2)	1.38 (35.1)
35-17.00 / 3.5	17 (431.8)	35 (889.0)	3.5 (88.9)	32.625 (828.7)	10.312 (261.9)	3.567 (90.6)	30.875 (784.2)	1.38 (35.1)
49-17.00 / 3.5	17 (431.8)	49 (1,244.6)	3.5 (88.9)	46.625 (1,184.3)	10.61 (269.5)	3.567 (90.6)	44.875 (1,139.8)	1.38 (35.1)
49-19.50 / 4.0	19.5 (495.3)	49 (1,244.6)	4 (101.6)	46.625 (1,184.3)	12 (304.8)	3.567 (90.6)	44.875 (1,139.8)	1.38 (35.1)

Rim Size	Fits Tire Size	Assembly Weight	Part Numbers				
			RIM BASE	BEAD SEAT	SIDE FLANGE	LOCK RING	O-RING
DIAMETER-WIDTH / FLANGE HEIGHT		LBS (KG)					
33-13.00 / 2.5	18.00-33	557.2 (14,152.9)	B1333RWHGD	BB33RTGN	S2533	LR33W	OR333T
35-15.00 / 3.0	21.00-35	669.3 (17,000.2)	B1535RWHGD	BB35RTG	S3035	LR35W	OR335T
35-17.00 / 3.5	24.00-35	734.5 (18,656.3)	B1735RWHGD	BB35RTG	S3535	LR35W	OR335T
49-17.00 / 3.5	24.00-49	1,099.5 (27,927.3)	B1749RWHGD	BB49RTG	H3549A	LR49W	OR349T
49-19.50 / 4.0	27.00-49	1,196.2 (30,383.5)	B1949RWHGD	BB49RTG	R4049EH	LR49W	OR349T

35"-49" MRW

5-PIECE RIM ASSEMBLIES

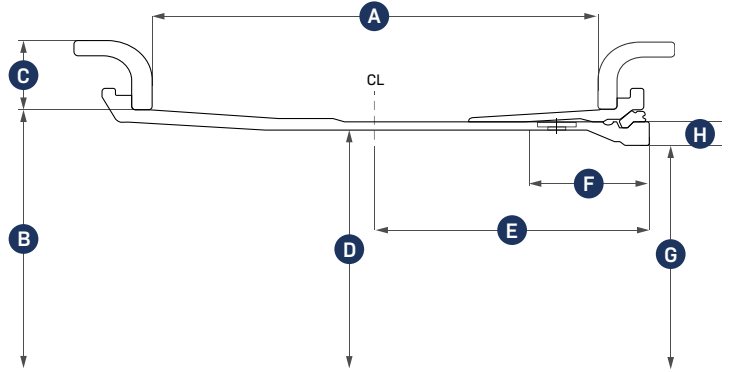

Rim Size	Dimensions							
	A	B	C	D	E	F	G	H
DIAMETER-WIDTH / FLANGE HEIGHT	IN (MM)	IN (MM)	IN (MM)	IN (MM)	IN (MM)	IN (MM)	IN (MM)	IN (MM)
35-15.00 / 3.0	15 (381.0)	35 (889.0)	3 (76.2)	32.625 (828.7)	9.65 (245.1)	4.125 (104.8)	30.312 (769.9)	1.78 (45.2)
35-17.00 / 3.5	17 (431.8)	35 (889.0)	3.5 (88.9)	32.625 (828.7)	10.59 (269.0)	4.125 (104.8)	30.312 (769.9)	1.78 (45.2)
49-17.00 / 3.5	17 (431.8)	49 (1,244.6)	3.5 (88.9)	46.625 (1,184.3)	10.61 (269.5)	4.125 (104.8)	44.062 (1,119.2)	1.78 (45.2)
49-19.50 / 4.0	19.5 (495.3)	49 (1,244.6)	4 (101.6)	46.625 (1,184.3)	12 (304.8)	4.125 (104.8)	44.062 (1,119.2)	1.78 (45.2)
49-19.50 / 4.0 (RWEG)	19.5 (495.3)	49 (1,244.6)	4 (101.6)	46.625 (1,184.3)	12 (304.8)	N/A	44.062 (1,119.2)	1.78 (45.2)

Rim Size	Fits Tire Size	Assembly Weight	Part Numbers				
			RIM BASE	BEAD SEAT	SIDE FLANGE	LOCK RING	O-RING
DIAMETER-WIDTH / FLANGE HEIGHT		LBS (KG)					
35-15.00 / 3.0	21.00-35	672 (17,068.8)	B1535MRWEGD	BB35RTG	S3035	LR35W	OR335T
35-17.00 / 3.5	24.00-35	734 (18,643.6)	B1735MRWEGD	BB35RTG	S3535	LR35W	OR335T
49-17.00 / 3.5	24.00-49	1,141.5 (28,994.1)	B1749MRWEGD	BB49RTG	H3549A	LR49W	OR349T
49-19.50 / 4.0	27.00-49	1,339.8 (34,030.9)	B1949RWEG	BB49RTG	R4049EH	LR49W	OR349T
49-19.50 / 4.0	27.00-49	1,331.6 (33,822.6)	B1949MRWEGD	BB49RTG	R4049EH	LR49W	OR349T



51"-57" STANDARD

5-PIECE RIM ASSEMBLIES

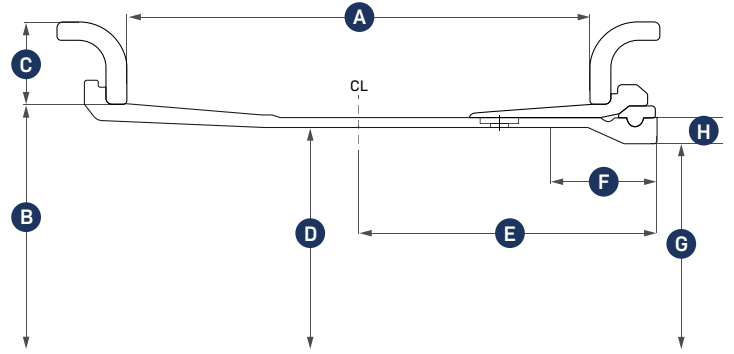

Rim Size	Dimensions							
	A	B	C	D	E	F	G	H
DIAMETER-WIDTH / FLANGE HEIGHT	IN (MM)	IN (MM)	IN (MM)	IN (MM)	IN (MM)	IN (MM)	IN (MM)	IN (MM)
51-22.00 / 4.5	22 (558.8)	51 (1,295.4)	4.5 (114.3)	47.75 (1,212.9)	14.875 (377.8)	5.86 (148.8)	45.218 (1,148.5)	1.86 (47.2)
51-24.00 / 5.0	24 (609.6)	51 (1,295.4)	5 (127.0)	47.75 (1,212.9)	15.875 (403.2)	5.86 (148.8)	45.218 (1,148.5)	1.86 (47.2)
51-26.00 / 5.0	26 (660.4)	51 (1,295.4)	5 (127.0)	47.75 (1,212.9)	16.875 (428.6)	5.86 (148.8)	45.218 (1,148.5)	1.86 (47.2)
51-32.00 / 4.5	32 (812.8)	51 (1,295.4)	4.5 (114.3)	47.75 (1,212.9)	19.875 (504.8)	5.86 (148.8)	45.218 (1,148.5)	1.86 (47.2)
51-40.00 / 4.5	40 (1,016.0)	51 (1,295.4)	4.5 (114.3)	47.75 (1,212.9)	23.875 (606.4)	5.86 (148.8)	45.218 (1,148.5)	1.86 (47.2)
57-27.00 / 6.0	27 (685.8)	57 (1,447.8)	6 (152.4)	53.75 (1,365.3)	17.375 (441.3)	5.86 (148.8)	51.218 (1,300.9)	1.86 (47.2)
57-29.00 / 6.0	29 (736.6)	57 (1,447.8)	6 (152.4)	53.75 (1,365.3)	18.375 (466.7)	5.86 (148.8)	51.218 (1,300.9)	1.86 (47.2)

Rim Size	Fits Tire Size	Assembly Weight	Part Numbers				
			RIM BASE	BEAD SEAT	SIDE FLANGE	LOCK RING	O-RING
DIAMETER-WIDTH / FLANGE HEIGHT		LBS (KG)					
51-22.00 / 4.5	30.00-51	1,975 (50,165.0)	B2251EHD	BB51EHD	H4551	LR51HD	OR451T
51-24.00 / 5.0	33.00-51	2,255 (57,277.0)	B2451EHD	BB51EHD	R5051H	LR51HD	OR451T
51-26.00 / 5.0	36.00-51	2,313 (58,750.2)	B2651EHD	BB51EHD	R5051H	LR51HD	OR451T
51-32.00 / 4.5	37.5-51	2,325 (59,055.0)	B3251EHD	BB51EHD	H4551	LR51HD	OR451T
51-40.00 / 4.5	50.00-51 50/65-51	2,540 (64,516.0)	B4051EHD	BB51EHD	R4551H	LR51HD	OR451T
57-27.00 / 6.0	37.00-57	2,800 (71,120.0)	B2757EHD	BB57EHD	R6057H	LR57HD	OR457T
57-29.00 / 6.0	40.00-57	2,940 (74,676.0)	B2957EHD	BB57EHD	R6057H	LR57HD	OR457T

51"-57" HEAVY-DUTY

5-PIECE RIM ASSEMBLIES

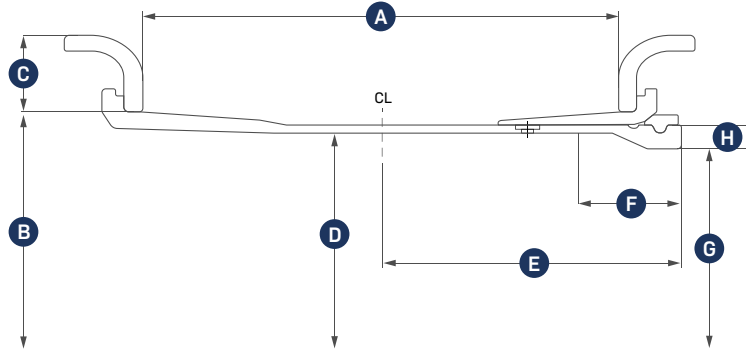

Rim Size	Dimensions							
	A	B	C	D	E	F	G	H
DIAMETER-WIDTH / FLANGE HEIGHT	IN (MM)	IN (MM)	IN (MM)	IN (MM)	IN (MM)	IN (MM)	IN (MM)	IN (MM)
51-22.00 / 4.5	22 (558.8)	51 (1,295.4)	4.5 (114.3)	47.75 (1,212.9)	14.875 (377.8)	5.86 (148.8)	45.218 (1,148.5)	1.86 (47.2)
51-24.00 / 5.0	24 (609.6)	51 (1,295.4)	5 (127.0)	47.75 (1,212.9)	15.875 (403.2)	5.86 (148.8)	45.218 (1,148.5)	1.86 (47.2)
51-26.00 / 5.0	26 (660.4)	51 (1,295.4)	5 (127.0)	47.75 (1,212.9)	16.875 (428.6)	5.86 (148.8)	45.218 (1,148.5)	1.86 (47.2)
51-32.00 / 4.5	32 (812.8)	51 (1,295.4)	4.5 (114.3)	47.75 (1,212.9)	19.875 (504.8)	5.86 (148.8)	45.218 (1,148.5)	1.86 (47.2)
51-40.00 / 4.5	40 (1,016.0)	51 (1,295.4)	4.5 (114.3)	47.75 (1,212.9)	23.875 (606.4)	5.86 (148.8)	45.218 (1,148.5)	1.86 (47.2)
57-27.00 / 6.0	27 (685.8)	57 (1,447.8)	6 (152.4)	53.75 (1,365.3)	17.375 (441.3)	5.86 (148.8)	51.218 (1,300.9)	1.86 (47.2)
57-29.00 / 6.0	29 (736.6)	57 (1,447.8)	6 (152.4)	53.75 (1,365.3)	18.375 (466.7)	5.86 (148.8)	51.218 (1,300.9)	1.86 (47.2)

Rim Size	Fits Tire Size	Assembly Weight	Part Numbers				
			RIM BASE	BEAD SEAT	SIDE FLANGE	LOCK RING	O-RING
DIAMETER-WIDTH / FLANGE HEIGHT		LBS (KG)					
51-22.00 / 4.5	30.00-51	2,316 (58,826.4)	514879201	5148704-50	5347396-50	LR51HD	OR451T
51-24.00 / 5.0	33.00-51	2,599 (66,014.6)	514878101	5148704-50	5348389-00	LR51HD	OR451T
51-26.00 / 5.0	36.00-51	2,646 (67,208.4)	514878201	5148704-50	5348389-00	LR51HD	OR451T
51-40.00 / 4.5	50.00-51 50/65-51	3,169 (80,492.6)	514886401	5148865-00	5348389-00	LR51HD	OR451T
57-27.00 / 6.0	37.00-57	3,167 (80,441.8)	514885201	5148732-50	5348388-50	LR57HD	OR457T
57-29.00 / 6.0	40.00-57	3,204 (81,381.6)	514885501	5148732-50	5348388-50	LR57HD	OR457T

63" STANDARD

5-PIECE RIM ASSEMBLIES

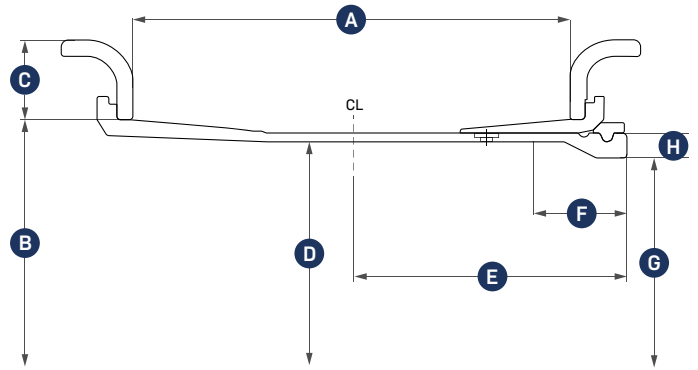

Rim Size	Dimensions							
	A	B	C	D	E	F	G	H
DIAMETER-WIDTH / FLANGE-HEIGHT	IN (MM)	IN (MM)	IN (MM)	IN (MM)	IN (MM)	IN (MM)	IN (MM)	IN (MM)
63-36.00 / 5.0	36 (914.4)	63 (1,600.2)	5 (127.0)	59 (1,498.6)	20.78 (527.8)	7.86 (199.6)	56.31 (1,430.3)	2.31 (2.31)

Rim Size	Fits Tire Size	Assembly Weight	Part Numbers				
DIAMETER-WIDTH / FLANGE-HEIGHT		LBS (KG)	RIM BASE	BEAD SEAT	SIDE FLANGE	LOCK RING	O-RING
63-36.00 / 5.0	53/80 R63	4,657 (1,118.287.8)	WB633650501	515083950	R5063HMS	LR63HD	OR463T

63" HEAVY-DUTY

5-PIECE RIM ASSEMBLIES

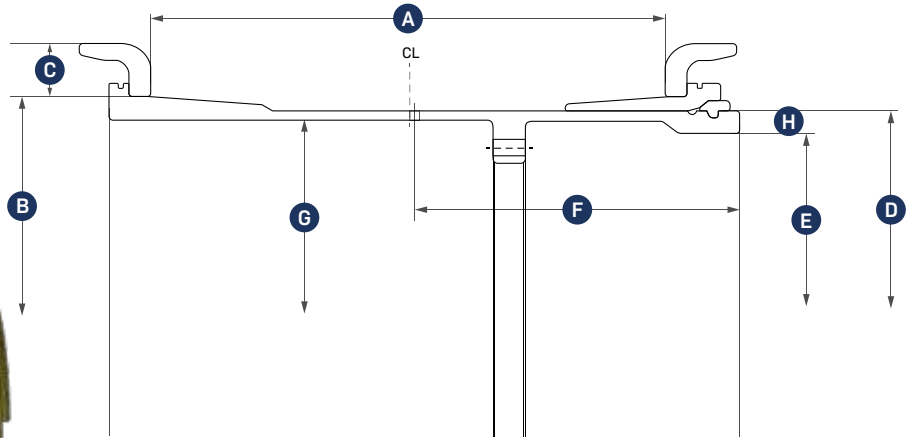
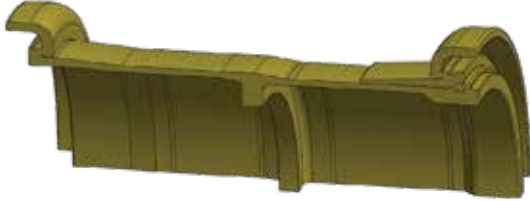

Rim Size	Dimensions							
	A	B	C	D	E	F	G	H
DIAMETER-WIDTH / FLANGE-HEIGHT	IN (MM)	IN (MM)	IN (MM)	IN (MM)	IN (MM)	IN (MM)	IN (MM)	IN (MM)
63-36.00 / 5.0	36 (914.4)	63 (1,600.2)	5 (127.0)	60.417 (1,534.6)	55.772 (1,416.6)	15.75 (400.1)	59.646 (1,515.0)	2.32 (58.9)
63-41.00 / 5.0	41 (1,048.4)	63 (1,600.2)	5 (127.0)	60.417 (1,534.6)	55.772 (1,416.6)	15.75 (400.1)	59.646 (1,515.0)	2.32 (58.9)
63-44.00 / 5.0	44 (1,117.6)	63 (1,600.2)	5 (127.0)	60.417 (1,534.6)	55.772 (1,416.6)	15.75 (400.1)	59.646 (1,515.0)	2.32 (58.9)

Rim Size	Fits Tire Size	Assembly Weight	Part Numbers				
			RIM BASE	BEAD SEAT	SIDE FLANGE	LOCK RING	O-RING
DIAMETER-WIDTH / FLANGE-HEIGHT		LBS (KG)					
63-36.00 / 5.0	53/80 R63	6,570 (166,878.0)	WB633650504	WBB056302	WSR506303	LR63HDS	OR463T
63-41.00 / 5.0	55/80 R63	6,593 (167,462.2)	WB634150504	WBB056302	WSR506303	LR63HDS	OR463T
63-44.00 / 5.0	58/80 R63 59/80 R63	6,615 (168,021.0)	WB634450504	WBB056302	WSR506303	LR63HDS	OR463T



63" HEAVY-DUTY TAPERED

5-PIECE RIM ASSEMBLIES

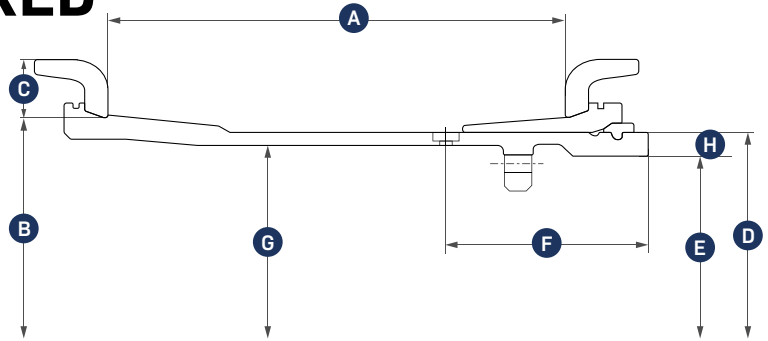

Rim Size	Dimensions							
	A	B	C	D	E	F	G	H
DIAMETER-WIDTH / FLANGE-HEIGHT	IN (MM)	IN (MM)	IN (MM)	IN (MM)	IN (MM)	IN (MM)	IN (MM)	IN (MM)
63-36.00 / 5.0	36 (914.4)	63 (1,600.2)	5 (127.0)	60.417 (1,534.6)	56.365 (1,431.7)	20.25 (514.4)	58.512 (1,486.2)	2.03 (51.6)
63-36.00 / 5.0	36 (914.4)	63 (1,600.2)	5 (127.0)	60.417 (1,534.6)	55.787 (1,417.0)	13.58 (344.9)	58.512 (1,486.2)	2.32 (58.9)
63-41.00 / 5.0	41 (1,041.4)	63 (1,600.2)	5 (127.0)	60.417 (1,534.6)	56.11 (1,425.2)	25.98 (659.9)	58.512 (1,486.2)	2.15 (54.6)
63-44.00 / 5.0	44 (1,117.6)	63 (1,600.2)	5 (127.0)	60.417 (1,534.6)	55.772 (1,416.6)	15.77 (400.6)	59.645 (1,515.0)	2.32 (58.9)

Rim Size	Fits Tire Size	Assembly Weight	Part Numbers				
			LBS (KG)	RIM BASE	BEAD SEAT	SIDE FLANGE	LOCK RING
DIAMETER-WIDTH / FLANGE-HEIGHT							
63-36.00 / 5.0	53/80R63	6,262 (159,054.8)	WB6336501	BB056302	SR506304	LR056303	OR463T
63-36.00 / 5.0	53/80R63	5,821 (147,853.4)	WB6336510	BB056302	SR506304	LR056303	OR463T
63-41.00 / 5.0	55/80R63	6,493 (164,922.2)	WB6341504	BB056302	SR506304	LR056303	OR463T
63-44.00 / 5.0	58/80R63	6,592 (167,436.8)	WB6344503	BB056302	SR506304	LR056303	OR463T

TLS HD

5-PIECE RIM ASSEMBLIES

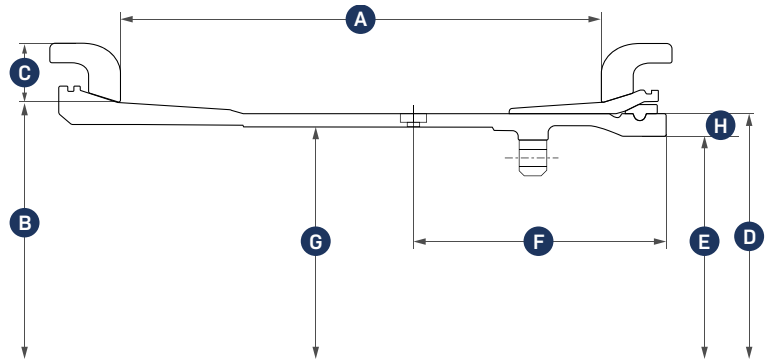
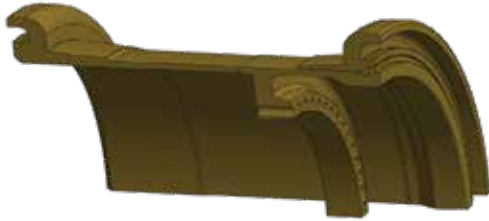

Rim Size	Dimensions							
	A	B	C	D	E	F	G	H
DIAMETER-WIDTH / FLANGE HEIGHT	IN (MM)	IN (MM)	IN (MM)	IN (MM)	IN (MM)	IN (MM)	IN (MM)	IN (MM)
57-29.00 / 6.0	29 (736.6)	57 (1,447.8)	6 (152.4)	54.94 (1,395.5)	51.25 (1,301.8)	11.5 (292.1)	53 (1,346.2)	1.84 (46.7)
63-36.00 / 5.0	36 (914.4)	63 (1,600.2)	5 (127.0)	60.937 (1,547.8)	56.5 (1,435.1)	23.67 (601.2)	59.031 (1,499.4)	2.22 (56.4)
63-41.00 / 5.0	41 (1,041.4)	63 (1,600.2)	5 (127.0)	60.937 (1,547.8)	56.5 (1,435.1)	26.18 (665.0)	59.031 (1,499.4)	2.22 (56.4)
63-44.00 / 5.0	44 (1,117.6)	63 (1,600.2)	5 (127.0)	60.937 (1,547.8)	57 (1,447.8)	15.77 (400.6)	59 (1,498.6)	1.97 (50.0)

Rim Size	Fits Tire Size	Assembly Weight	Part Numbers				
			RIM BASE	BEAD SEAT	SIDE FLANGE	LOCK RING	O-RING
DIAMETER-WIDTH / FLANGE HEIGHT		LBS (KG)					
57-29.00 / 6.0	40.00-57	4,520 (114,808.0)	WB5729518	BB055710	SR605702	LR055703	OR463T
63-36.00 / 5.0	53/80R63	6,788 (172,415.2)	WB6336507	BB056308	SR506305	LR056304	OR463T
63-41.00 / 5.0	55/80R63	7,053 (179,146.2)	WB6341505	BB056308	SR506305	LR056304	OR463T
63-44.00 / 5.0	55/80R63	6,674 (169,519.6)	WB6344505	BB056308	SR506305	LR056304	OR463T

Tapered Lock System

OTR's tapered lock system (TLS) type rim assemblies are available in 5-, 6-, and 7-piece configurations that are compatible with competitors' models, as form-fit-function replacements for stock rims as well. HSLA-grade steel is used for critical components with seamless forged gutters and fully machined sections yielding a best-in-class solution for mining vehicles and earthmoving equipment.

STANDARD

5-PIECE RIM ASSEMBLIES

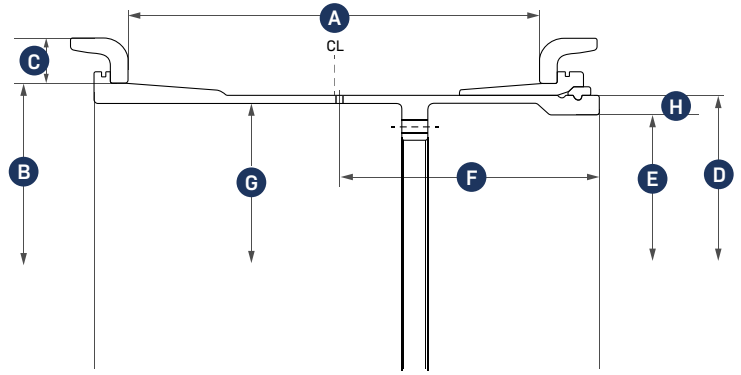

Rim Size	Dimensions							
	A	B	C	D	E	F	G	H
DIAMETER-WIDTH / FLANGE HEIGHT	IN (MM)	IN (MM)	IN (MM)	IN (MM)	IN (MM)	IN (MM)	IN (MM)	IN (MM)
63-36.00 / 5.0	36 (914.4)	63 (1,600.2)	5 (127.0)	60.417 (1,534.6)	55.787 (1,417.0)	14.811 (376.2)	58.504 (1,486.0)	2.32 (58.9)
63-41.00 / 5.0	41 (1,041.4)	63 (1,600.2)	5 (127.0)	60.417 (1,534.6)	56.11 (1,425.2)	25.984 (660.0)	58.504 (1,486.0)	2.15 (54.6)
63-44.00 / 5.0	44 (1,117.6)	63 (1,600.2)	5 (127.0)	60.417 (1,534.6)	55.771 (1,416.6)	15.768 (400.5)	59.646 (1,515.0)	2.32 (58.9)

Rim Size	Fits Tire Size	Assembly Weight	Part Numbers				
			RIM BASE	BEAD SEAT	SIDE FLANGE	LOCK RING	O-RING
DIAMETER-WIDTH / FLANGE HEIGHT	TIRE SIZE	LBS (KG)					
63-36.00 / 5.0	53/80R63	6,295 (159,893.0)	WB6336511	BB056301	SR506303	LR056302	OR463T
63-41.00 / 5.0	55/80R63	6,696 (170,078.4)	WB6341503	BB056301	SR506303	LR056302	OR463T
63-44.00 / 5.0	58/80R63	6,502 (165,150.8)	WB6344502	BB056301	SR506303	LR056302	OR463T

Mining **Rim Assemblies**



TLS HD

6-PIECE RIM ASSEMBLIES

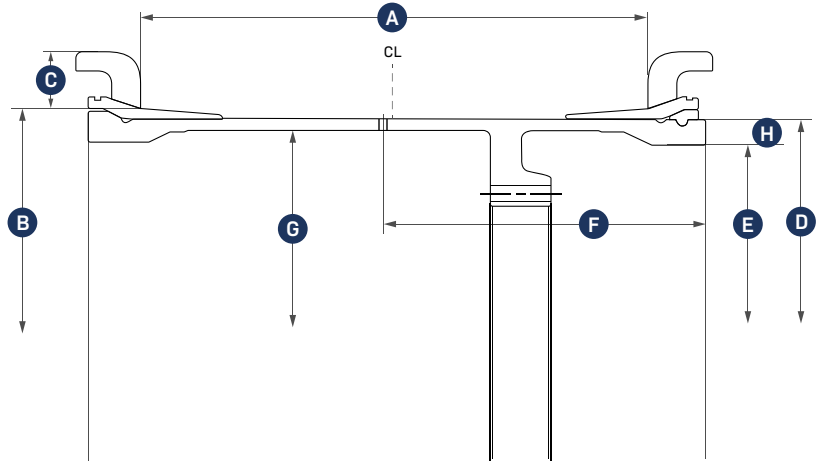

Rim Size	Dimensions							
	A	B	C	D	E	F	G	H
DIAMETER-WIDTH / FLANGE HEIGHT	IN (MM)	IN (MM)	IN (MM)	IN (MM)	IN (MM)	IN (MM)	IN (MM)	IN (MM)
57-29.00 / 6.0	29 (736.6)	57 (1,447.8)	6 (152.4)	54.94 (1,395.5)	51.25 (1,301.8)	12 (304.8)	53 (1,346.2)	1.84 (46.7)
63-36.00 / 5.0	36 (914.4)	63 (1,600.2)	5 (127.0)	60.937 (1,547.8)	56.5 (1,435.1)	23.661 (601.0)	58.969 (1,497.8)	2.22 (56.4)
63-41.00 / 5.0	41 (1,041.4)	63 (1,600.2)	5 (127.0)	60.937 (1,547.8)	56.5 (1,435.1)	26.181 (665.0)	58.969 (1,497.8)	2.22 (56.4)
63-44.00 / 5.0	44 (1,117.6)	63 (1,600.2)	5 (127.0)	60.937 (1,547.8)	55.772 (1,416.6)	15.748 (400.0)	58.969 (1,497.8)	2.58 (65.5)

Rim Size	Fits Tire Size	Assembly Weight	Part Numbers				
			RIM BASE	BEAD SEAT	SIDE FLANGE	LOCK RING	O-RING
DIAMETER-WIDTH / FLANGE HEIGHT		LBS (KG)					
57-29.00 / 6.0	40.00-57 46/90R57	5097 (2,312.0)	WB5728601	BB055710	SR605702	LR055703	OR463T
63-36.00 / 5.0	53/80R63	6945 (3,150.2)	WB6336604	BB056308	SR506305	LR056304	OR463T
63-41.00 / 5.0	55/80R63	7192 (3,262.2)	WB6341603	BB056308	SR506305	LR056304	OR463T
63-44.00 / 5.0	58/80R63	7007 (3,178.3)	WB6344601	BB056308	SR506305	LR056304	OR463T

TLS HD

7-PIECE RIM ASSEMBLIES

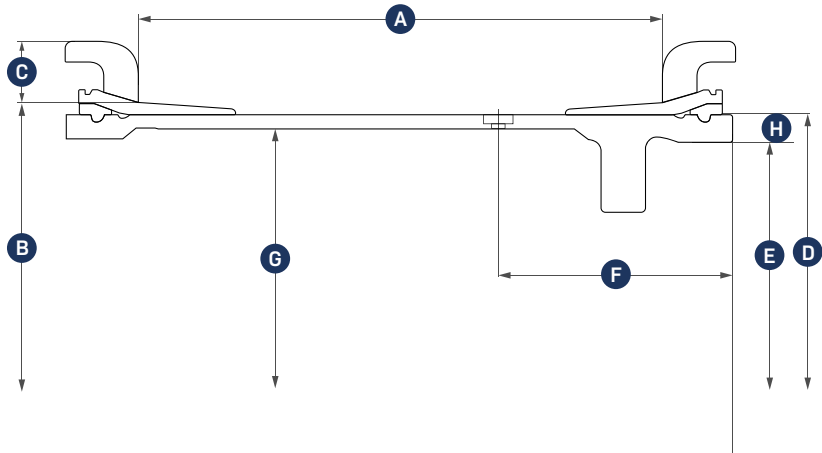

Rim Size	Dimensions							
	A	B	C	D	E	F	G	H
DIAMETER-WIDTH / FLANGE HEIGHT	IN (MM)	IN (MM)	IN (MM)	IN (MM)	IN (MM)	IN (MM)	IN (MM)	IN (MM)
57-29.00 / 6.0	29 (736.6)	57 (1,447.8)	6 (152.4)	54.937 (1,395.4)	51.248 (1,301.7)	11.63 (295.4)	53 (1,346.2)	1.84 (46.7)
63-36.00 / 5.0	36 (914.4)	63 (1,600.2)	5 (127.0)	60.937 (1,547.8)	56.5 (1,435.1)	23.671 (601.2)	59.031 (1,499.4)	2.22 (56.4)
63-41.00 / 5.0	41 (1,041.4)	63 (1,600.2)	5 (127.0)	60.937 (1,547.8)	56.5 (1,435.1)	26.171 (664.7)	59.031 (1,499.4)	2.22 (56.4)
63-44.00 / 5.0	44 (1,117.6)	63 (1,600.2)	5 (127.0)	60.937 (1,547.8)	57 (1,447.8)	15.748 (400.0)	58.969 (1,497.8)	1.97 (50.0)

Rim Size	Fits Tire Size	Assembly Weight	Part Numbers				
			RIM BASE	BEAD SEAT	SIDE FLANGE	LOCK RING	O-RING
DIAMETER-WIDTH / FLANGE HEIGHT		LBS (KG)					
57-29.00 / 6.0	40.00-57 46/90R57	5331 (2,418.1)	WB5729701	BB055710	SR605702	LR055703	OR463T
63-36.00 / 5.0	53/80R63	7055 (3,200.1)	WB6336706	BB056308	SR506305	LR056304 LR056306	OR463T
63-41.00 / 5.0	55/80R63	7300 (3,311.2)	WB6341707	BB056308	SR506305	LR056304 LR056306	OR463T
63-44.00 / 5.0	58/80R63	6874 (3,118.0)	WB6344702	BB056308	SR506305	LR056304 LR056306	OR463T



STANDARD

7-PIECE RIM ASSEMBLIES

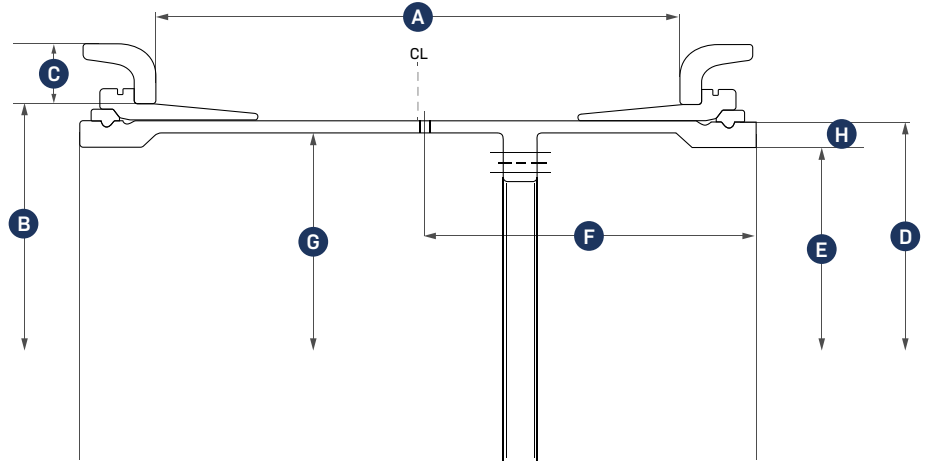

Rim Size	Dimensions							
	A	B	C	D	E	F	G	H
DIAMETER-WIDTH / FLANGE HEIGHT	IN (MM)	IN (MM)	IN (MM)	IN (MM)	IN (MM)	IN (MM)	IN (MM)	IN (MM)
63-36.00 / 5.0	36 (914.4)	63 (1,600.2)	5 (127.0)	60.417 (1,534.6)	55.787 (1,417.0)	14.811 (376.2)	58.504 (1,486.0)	2.32 (58.9)
63-41.00 / 5.0	41 (1,041.4)	63 (1,600.2)	5 (127.0)	60.417 (1,534.6)	56.11 (1,425.2)	25.984 (660.0)	58.504 (1,486.0)	2.15 (54.6)
63-44.00 / 5.0	44 (1,117.6)	63 (1,600.2)	5 (127.0)	60.417 (1,534.6)	55.771 (1,416.6)	15.768 (400.5)	58.504 (1,486.0)	2.32 (58.9)

Rim Size	Fits Tire Size	Assembly Weight	Part Numbers				
			RIM BASE	BEAD SEAT	SIDE FLANGE	LOCK RING	O-RING
DIAMETER-WIDTH / FLANGE HEIGHT		LBS (KG)					
63-36.00 / 5.0	53/80R63	6846 (3,105.3)	WB6336705	BB056301	SR506303	LR056302 LR056305	OR463T
63-41.00 / 5.0	55/80R63	7240 (3,284.0)	WB6341706	BB056301	SR506303	LR056302 LR056324	OR463T
63-44.00 / 5.0	58/80R63	7551 (3,425.1)	WB6344701	BB056301	SR506303	LR056302 LR056305	OR463T

DOUBLE-GUTTER WHEELS

OTR designs and manufactures 7-piece double-gutter steel mining wheels ranging in size from 57" to 63", enabling easy demounting without having to remove the inside tire in a dual-tire configuration. Wheel sizes and configurations are compatible with industry standards and popular fitments for retrofitting fleets. Wheels include an integrated Sur-Loc system to prevent inflation if using an incorrectly mounted lock ring. As a result, wheel demounting and operation is safe and efficient.



TIME SAVINGS

Standard mining wheels take, on average, 165 minutes to demount and set up versus OTR's wheel design, which takes less than half that time, saving up to 85 valuable minutes. This ensures more productivity and utilization for vehicles and machines — **the ideal solution for fleets operating 24/7.**

Components

25" Side Rings

FOR 3-PIECE RIMS/WHEELS

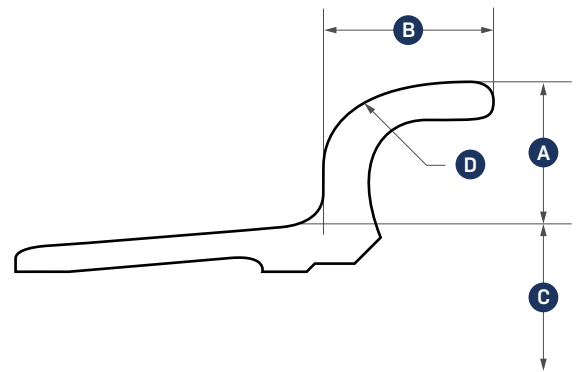

Rim Diameter	Dimensions				Weight	Part Number
	A	B-Min	C	D		
IN (MM)	IN (MM)	IN (MM)	IN (MM)	IN (MM)	LBS (KG)	
25	1.3 (33.0)	1.63 (41.4)	24.95 (633.7)	0.9 (22.9)	35.3 (16.0)	F25TU 1.3
25	1.7 (43.2)	0.97 (24.6)	25 (635.0)	0.9 (22.9)	54.6 (24.8)	F25TG
25	1.5 (38.1)	1.07 (27.2)	25 (635.0)	1 (25.4)	42.2 (19.1)	F1025T
25	1.7 (43.2)	0.97 (24.6)	25 (635.0)	0.9 (22.9)	54.6 (24.8)	SF1725TU

25" Lock Rings

FOR 3-PIECE RIMS/WHEELS

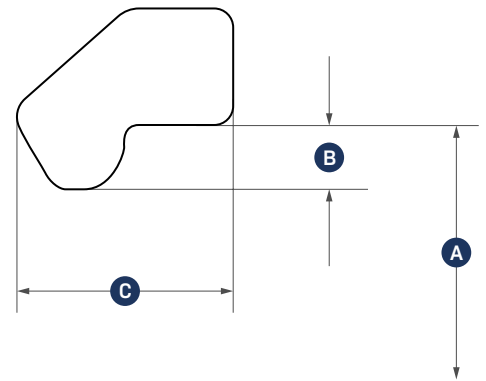

Rim Diameter	Dimensions			Weight	Part Number
	A	B-Min	C		
IN (MM)	IN (MM)	IN (MM)	IN (MM)	LBS (KG)	
25	23.6 (599.4)	0.22 (5.6)	0.63 (16.0)	5.42 (137.7)	LR25T



25" & 29" Flanges

FOR 5-PIECE RIMS/WHEELS

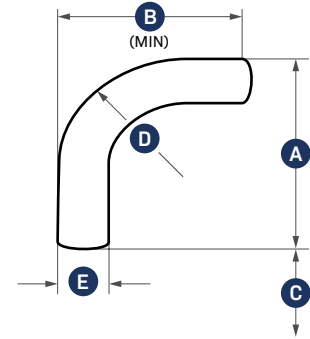

Rim Diameter	Dimensions					Weight	Part Number
	A	B-Min	C	D	E		
IN (MM)	IN (MM)	IN (MM)	IN (MM)	IN (MM)	IN (MM)	LBS (KG)	
25	2 (50.8)	1.25 (31.8)	25 (635.0)	1.25 (31.8)	0.5 (12.7)	28.1 (12.7)	S2025
25	2.5 (63.5)	1.75 (44.5)	25 (635.0)	1.5 (38.1)	0.63 (16.0)	44.5 (20.2)	S2525
25	3 (76.2)	2.13 (54.1)	25 (635.0)	1.75 (44.5)	0.63 (16.0)	56.2 (25.5)	S3025
25	3.5 (88.9)	2.25 (57.2)	25 (635.0)	2 (50.8)	0.63 (16.0)	66.8 (30.3)	S3525
29	3 (76.2)	2.13 (54.1)	29 (736.6)	1.75 (44.5)	0.63 (16.0)	63.7 (28.9)	S3029
29	3.5 (88.9)	2.25 (57.2)	29 (736.6)	2 (50.8)	0.63 (16.0)	77 (34.9)	S3529

25" & 29" Lock Rings

FOR 5-PIECE RIMS/WHEELS

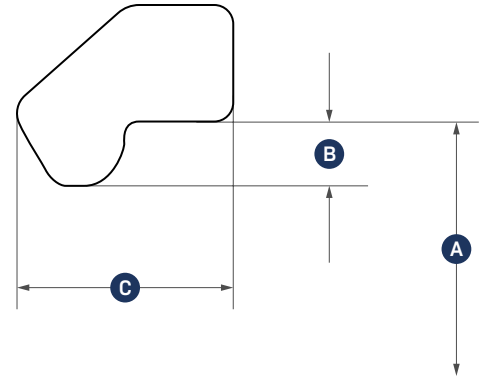

5TN Lock Ring

Rim Diameter	Dimensions			Driver Type	Weight	Part Number
	A	B-Min	C			
IN (MM)	IN (MM)	IN (MM)	IN (MM)		LBS (KG)	
25	23.2 (589.3)	0.34 (8.6)	0.97 (24.6)	CRIMPED	13 (330.2)	LR255TN
29	27.2 (690.9)	0.34 (8.6)	0.97 (24.6)	CRIMPED	15.2 (386.1)	LR295TN

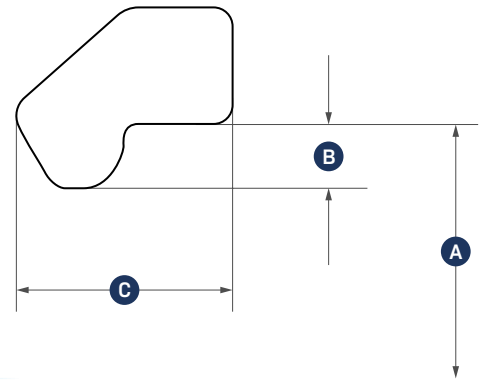

5TM Lock Ring

Rim Diameter	Dimensions			Weight	Part Number
	A	B-Min	C		
IN (MM)	IN (MM)	IN (MM)	IN (MM)	LBS (KG)	
25	23.2 (589.3)	0.34 (8.6)	0.97 (24.6)	12.2 (309.9)	LR255TM
29	27.2 (690.9)	0.34 (8.6)	0.97 (24.6)	14.2 (360.7)	LR295TM



25" & 29" Bead Seat Bands

FOR 5-PIECE RIMS/WHEELS

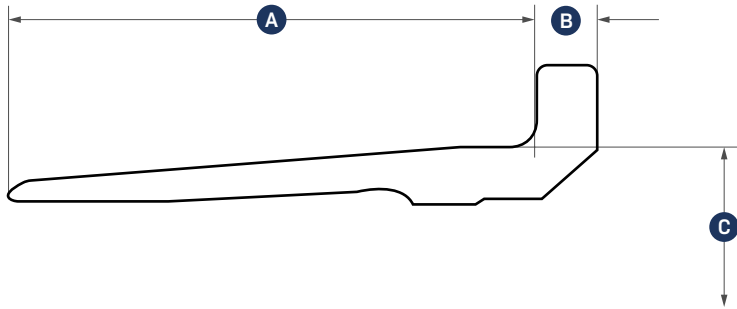

STN/HTN



ST31/HT31

Rim Diameter	Dimensions			Driver Type	Weight	Part Number
	A	B	C			
IN (MM)	IN (MM)	IN (MM)	IN (MM)		LBS (KG)	
25	5 (127.0)	0.56 (14.2)	25 (635.0)	NONE	58.4 (26.5)	BB25STG
25	5 (127.0)	0.56 (14.2)	25 (635.0)	NOTCH	58.4 (26.5)	BB25STN
25	5 (127.0)	0.56 (14.2)	25 (635.0)	OUTBOARD	58.3 (26.4)	BB25ST31
25	6.31 (160.3)	0.56 (14.2)	25 (635.0)	NONE	58.4 (26.5)	BB25HTG
25	6.31 (160.3)	0.65 (16.5)	25 (635.0)	NOTCH	70.1 (31.8)	BB25HTN
25	6.31 (160.3)	0.65 (16.5)	25 (635.0)	OUTBOARD	71.4 (32.4)	BB25HT31
29	6.31 (160.3)	0.65 (16.5)	29 (736.6)	NONE	81 (36.7)	BB29HTG
29	6.31 (160.3)	0.65 (16.5)	29 (736.6)	NOTCH	80 (36.3)	BB29HTN
29	6.31 (160.3)	0.65 (16.5)	29 (736.6)	OUTBOARD	82.1 (37.2)	BB29HT31

33"-49" Flanges

FOR 5-PIECE RIMS/WHEELS

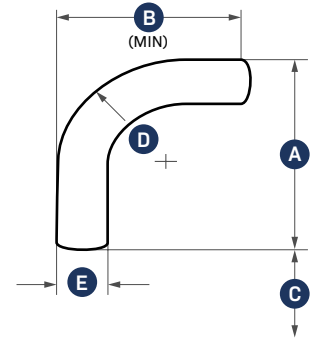

Rim Diameter	Dimensions					Weight	Part Number
	A	B-Min	C	D	E		
IN (MM)	IN (MM)	IN (MM)	IN (MM)	IN (MM)	IN (MM)	LBS (KG)	
33	2.5 (63.5)	1.75 (44.5)	33 (838.2)	1.5 (38.1)	0.63 (16.0)	58 (26.3)	S2533
33	3.5 (88.9)	2.25 (57.2)	33 (838.2)	2 (50.8)	0.63 (16.0)	87.6 (39.7)	S3533
33	4 (101.6)	2.56 (65.0)	33 (838.2)	2.25 (57.2)	0.75 (19.1)	119.6 (54.2)	S4033
33	4.5 (114.3)	2.88 (73.2)	33 (838.2)	2.5 (63.5)	0.75 (19.1)	139.4 (63.2)	S4533
35	3 (76.2)	2.13 (54.1)	35 (889.0)	1.75 (44.5)	0.63 (16.0)	77.4 (35.1)	S3035
35	3.5 (88.9)	2.25 (57.2)	35 (889.0)	2 (50.8)	0.63 (16.0)	92.8 (42.1)	S3535
35	4 (101.6)	2.56 (65.0)	35 (889.0)	2.25 (57.2)	0.75 (19.1)	128.4 (58.2)	S4035
39	4 (101.6)	2.56 (65.0)	39 (990.6)	2.25 (57.2)	0.75 (19.1)	144.2 (65.4)	S4039
39	4.5 (114.3)	2.88 (73.2)	39 (990.6)	2.5 (63.5)	0.75 (19.1)	164.8 (74.8)	S4539
45	4.5 (114.3)	2.88 (73.2)	45 (1,143.0)	2.5 (63.5)	0.75 (19.1)	188.8 (85.6)	S4545
45	4.5 (114.3)	3 (76.2)	45 (1,143.0)	2.25 (57.2)	0.71 (18.0)	185 (83.9)	S4545HF
45	4.5 (114.3)	3.4 (86.4)	45 (1,143.0)	2.5 (63.5)	1 (25.4)	269 (122.0)	R4545H
45	4.5 (114.3)	3.5 (88.9)	45 (1,143.0)	2.25 (57.2)	0.98 (24.9)	278 (126.1)	R4545EH
45	4.5 (114.3)	3.39 (86.1)	45 (1,143.0)	2.25 (57.2)	0.98 (24.9)	278 (126.1)	R4545HMS*
49	3.5 (88.9)	3.5 (88.9)	49 (1,244.6)	2 (50.8)	0.87 (22.1)	174 (78.9)	H3549A
49	4 (101.6)	3.31 (84.1)	49 (1,244.6)	2.25 (57.2)	0.87 (22.1)	220 (99.8)	H4049A
49	4 (101.6)	3.39 (86.1)	49 (1,244.6)	2.25 (57.2)	1.1 (27.9)	293 (132.9)	R4049EH
49	4 (101.6)	3.66 (93.0)	49 (1,244.6)	2.25 (57.2)	0.98 (24.9)	287 (130.2)	R4049HMS*

*HMS IS FOR HOT FORGED SEAMLESS RING.



33"-49" Lock Rings

FOR 5-PIECE RIMS/WHEELS

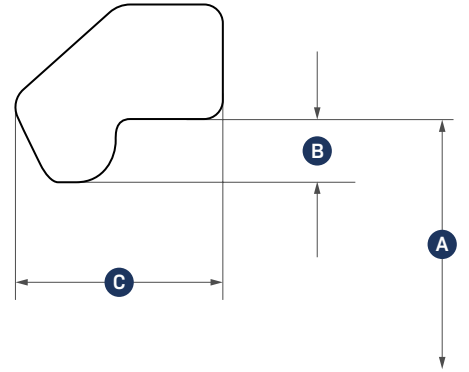

5TM Lock Ring

Rim Diameter	Dimensions			Weight	Part Number
	A	B-Min	C		
IN (MM)	IN (MM)	IN (MM)	IN (MM)	LBS (KG)	
33	31.2 (792.5)	0.34 (8.6)	0.97 (24.6)	16.2 (411.5)	LR335TM
35	33.2 (843.3)	0.34 (8.6)	0.97 (24.6)	17.2 (436.9)	LR355TM
39	37.4 (950.0)	0.34 (8.6)	0.97 (24.6)	19.4 (492.8)	LR395TM
45	43.2 (1,097.3)	0.34 (8.6)	0.97 (24.6)	20.9 (530.9)	LR455TM

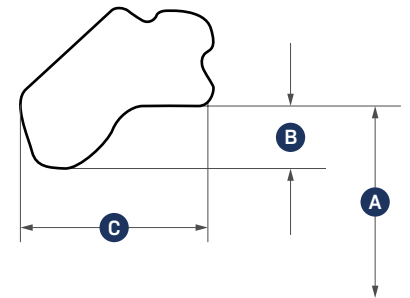

W Lock Ring

Rim Diameter	Dimensions			Weight	Part Number
	A	B-Min	C		
IN (MM)	IN (MM)	IN (MM)	IN (MM)	LBS (KG)	
33	31.1 (789.9)	0.38 (9.7)	1.1 (27.9)	19.7 (500.4)	LR33W
35	33.1 (840.7)	0.38 (9.7)	1.1 (27.9)	20.8 (528.3)	LR35W
49	47.1 (1,196.3)	0.38 (9.7)	1.1 (27.9)	29.8 (756.9)	LR49W

33"-49" Bead Seat Bands

FOR 5-PIECE RIMS/WHEELS

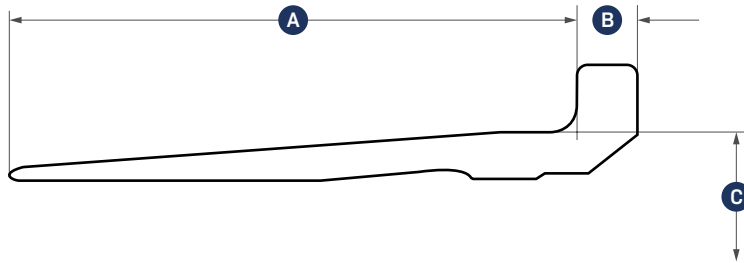

Rim Diameter	Dimensions			Driver Type	Weight	Part Number
	A	B	C			
IN (MM)	IN (MM)	IN (MM)	IN (MM)		LBS (KG)	
33	6.94 (176.3)	1.13 (28.7)	33 (838.2)	NONE	110.5 (50.1)	BB33RTG(N)*
33	6.94 (176.3)	1.13 (28.7)	33 (838.2)	OUTBOARD	111.8 (50.7)	BB33RTL
35	6.94 (176.3)	1.13 (28.7)	35 (889.0)	NONE	118.2 (53.6)	BB35RTG
39	6.94 (176.3)	1.13 (28.7)	39 (990.6)	OUTBOARD	132.6 (60.1)	BB39RTL
45	6.31 (160.3)	1.13 (28.7)	45 (1,143.0)	NONE	140 (63.5)	BB45RTG
45	6.31 (160.3)	1.13 (28.7)	45 (1,143.0)	OUTBOARD	142 (64.4)	BB45RTL**
49	6.94 (176.3)	1.13 (28.7)	49 (1,244.6)	NONE	165.1 (74.9)	BB49RTG

* (N) IDENTIFIES A BEAD SEAT WITH NOTCHES IN THE OUTER LIP FOR HYDRAULIC TOOL ACCESS (NECESSARY WHEN USED WITH 13.00-WIDE RIM ASSEMBLIES).

** IDENTIFIES BEAD SEAT WITH LARGE OUTBOARD DRIVER POCKET DP49A.



51" & 57" Flanges

FOR 5-PIECE RIMS/WHEELS

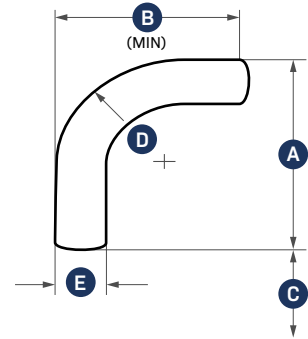

Rim Diameter	Dimensions					Weight	Part Number
	A	B-Min	C	D	E		
IN (MM)	IN (MM)	IN (MM)	IN (MM)	IN (MM)	IN (MM)	LBS (KG)	
51	4.5 (114.3)	2.88 (73.2)	51 (1,295.4)	2.5 (63.5)	0.88 (22.4)	245.2 (111.2)	H4551
51	4.5 (114.3)	3.16 (80.3)	51 (1,295.4)	2.5 (63.5)	0.71 (18.0)	271 (122.9)	S4551HF
51	4.5 (114.3)	3.16 (80.3)	51 (1,295.4)	2.5 (63.5)	0.98 (24.9)	518 (235.0)	R4551HMS SEAMLESS DESIGN
51	5 (127.0)	4.09 (103.9)	51 (1,295.4)	2.75 (69.9)	1.1 (27.9)	450 (204.1)	S5051HF
51	5 (127.0)	4 (101.6)	51 (1,295.4)	2.75 (69.9)	1 (25.4)	360 (163.3)	R5051H
57	5 (127.0)	5.16 (131.1)	51 (1,295.4)	2.75 (69.9)	1.26 (32.0)	573 (259.9)	R5051HMS SEAMLESS DESIGN
57	5 (127.0)	4.53 (115.1)	57 (1,447.8)	2.75 (69.9)	0.98 (24.9)	418.9 (190.0)	R5057H
57	5 (127.0)	5.2 (132.1)	57 (1,447.8)	2.75 (69.9)	1.1 (27.9)	496 (225.0)	S5057HF
57	5 (127.0)	5 (127.0)	57 (1,447.8)	2.75 (69.9)	1.2 (30.5)	577 (261.7)	R5057 HMS SEAMLESS DESIGN
57	6 (152.4)	5.2 (132.1)	57 (1,447.8)	2.75 (69.9)	1.1 (27.9)	555.6 (205.0)	R6057H
57	6 (152.4)	4.44 (112.8)	57 (1,447.8)	3.3 (83.8)	1 (25.4)	452 (205.0)	R6057EH
57	6 (152.4)	5.16 (131.1)	57 (1,447.8)	2.75 (69.9)	1.26 (32.0)	606.3 (275.0)	R6057HMS SEAMLESS DESIGN
57	6 (152.4)	5.16 (131.1)	57 (1,447.8)	2.75 (69.9)	1.26 (32.0)	617.3 (280.0)	R6557HMS SEAMLESS DESIGN
57	6.5 (165.1)	5.16 (131.1)	57 (1,447.8)	2.75 (69.9)	1.26 (32.0)	661.4 (300.0)	S6557HF

51" & 57" Lock Rings

FOR **5-PIECE** RIMS/WHEELS

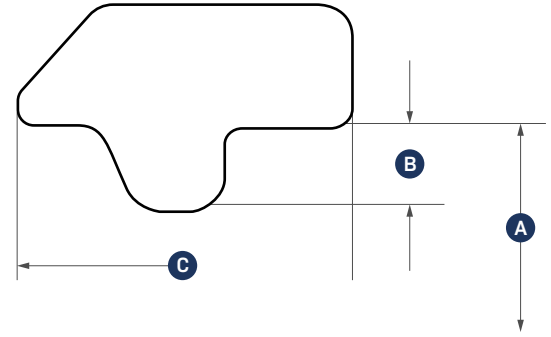

Rim Diameter	Dimensions			Weight	Part Number
	A	B-Min	C		
IN (MM)	IN (MM)	IN (MM)	IN (MM)	LBS (KG)	
51	48.7 (1,237.0)	0.55 (14.0)	2.31 (58.7)	94.6 (2,402.8)	LR51HD
57	54.7 (1,389.4)	0.55 (14.0)	2.31 (58.7)	105.8 (2,687.3)	LR57HD

TLS LOCK RINGS ARE ALSO AVAILABLE.

51" & 57" Bead Seat Bands with Sur-Loc

FOR **5-PIECE** RIMS/WHEELS

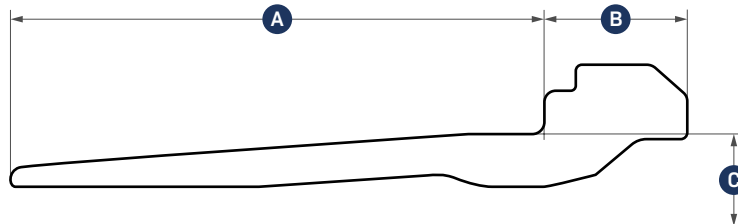

Rim Diameter	Dimensions			Driver Type	Weight	Part Number
	A	B	C			
IN (MM)	IN (MM)	IN (MM)	IN (MM)		LBS (KG)	
51	8.75 (222.3)	2.36 (59.9)	51.0 (1,295.4)	NONE	303.4 (137.6)	BB51EHD
57	8.75 (222.3)	2.36 (59.9)	57.0 (1,447.8)	NONE	338.0 (153.3)	BB57EHD



51" & 57" Bead Seat Bands HEAVY-DUTY

FOR 5-PIECE RIMS/WHEELS

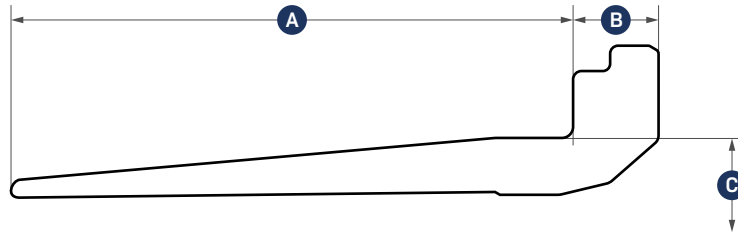

Rim Diameter	Dimensions			Driver Type	Weight	Part Number
	A	B	C			
IN (MM)	IN (MM)	IN (MM)	IN (MM)		LBS (KG)	
51	9.17 (232.9)	1.38 (35.1)	51.0 (1,295.4)	NONE	302.0 (137.0)	514870450
57	9.17 (232.9)	1.38 (35.1)	57.0 (1,447.8)	NONE	341.0 (154.7)	514873250

57" Bead Seat Bands with Sur-Loc

FOR 5-PIECE RIMS/WHEELS

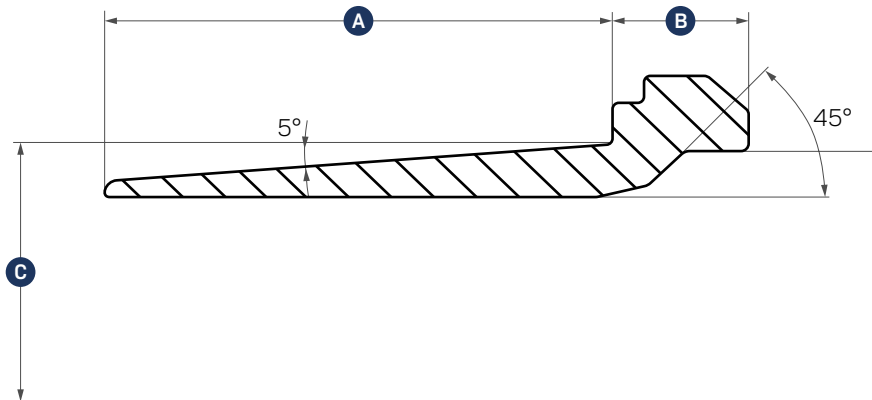

Rim Diameter	Dimensions			Driver Type	Weight	Part Number
	A	B	C			
IN (MM)	IN (MM)	IN (MM)	IN (MM)		LBS (KG)	
57	8.74 (222.0)	2.36 (59.9)	57 (1,447.8)	NONE	440 (199.6)	WBB055701

63" Flanges STANDARD

FOR 5-PIECE RIMS/WHEELS

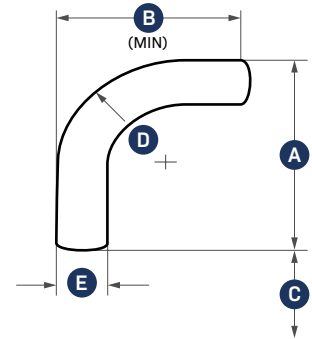

Rim Diameter	Dimensions					Weight	Part Number
	A	B-Min	C	D	E		
IN (MM)	IN (MM)	IN (MM)	IN (MM)	IN (MM)	IN (MM)	LBS (KG)	
63	5 (127.0)	5.59 (142.0)	57 (1,447.8)	2.75 (69.9)	1.1 (27.9)	610.7 (277.0)	S5063HF
63	5 (127.0)	5.51 (140.0)	63 (1,600.2)	2.75 (69.9)	1.38 (35.1)	670.2 (304.0)	R5063 HMS SEAMLESS DESIGN

63" Flanges HEAVY-DUTY

FOR 5-PIECE RIMS/WHEELS

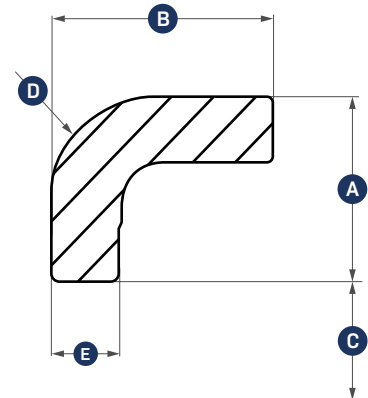

Rim Diameter	Dimensions					Weight	Part Number
	A	B-Min	C	D	E		
IN (MM)	IN (MM)	IN (MM)	IN (MM)	IN (MM)	IN (MM)	LBS (KG)	
63	5 (127.0)	5.512 (140.0)	63.051 (1,601.5)	2.75 (69.9)	1.69 (42.9)	836 (379.2)	WSR506303



63" Flanges HEAVY-DUTY TAPERED

FOR 5-PIECE RIMS/WHEELS

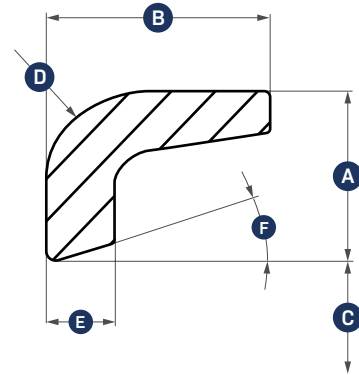

Rim Diameter	Dimensions					Weight	Part Number
	A	B-Min	C	D	E		
IN (MM)	IN (MM)	IN (MM)	IN (MM)	IN (MM)	IN (MM)	LBS (KG)	
63	5 (127.0)	5.512 (140.0)	63.051 (1,601.5)	2.75 (69.9)	1.75 (44.5)	790 (358.3)	WSR506304

63" Lock Rings STANDARD

FOR 5-PIECE RIMS/WHEELS

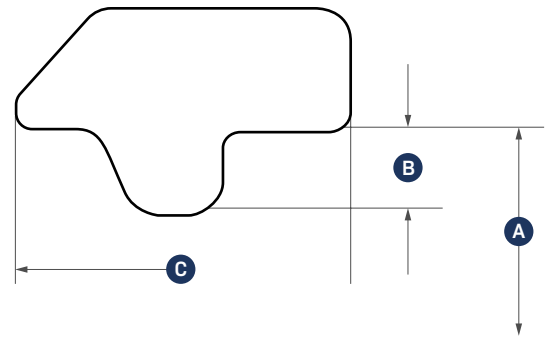

Rim Diameter	Dimensions			Weight	Part Number
	A	B-Min	C		
IN (MM)	IN (MM)	IN (MM)	IN (MM)	LBS (KG)	
63	60.7 (1,541.8)	0.55 (14.0)	2.31 (58.7)	116 (2,946.4)	LR63HD

63" (45°) Lock Rings HEAVY-DUTY TAPERED

FOR 5-PIECE RIMS/WHEELS

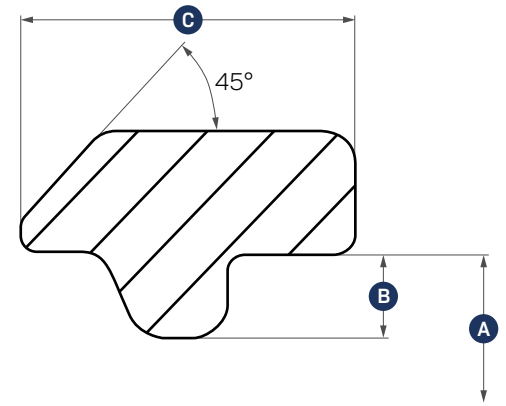

Rim Diameter	Dimensions			Weight	Part Number
	A	B-Min	C		
IN (MM)	IN (MM)	IN (MM)	IN (MM)	LBS (KG)	
63	60.417 (1,534.6)	0.551 (14.0)	2.307 (58.6)	116 (2,946.4)	LR63HDS

63" (35°) Lock Rings HEAVY-DUTY TAPERED

FOR 5-PIECE RIMS/WHEELS

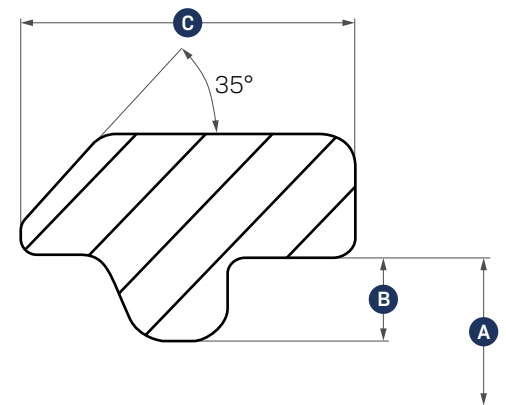

Rim Diameter	Dimensions			Weight	Part Number
	A	B-Min	C		
IN (MM)	IN (MM)	IN (MM)	IN (MM)	LBS (KG)	
63	60.417 (1,534.6)	0.551 (14.0)	2.307 (58.6)	116 (2,946.4)	LR63HDS35

63" Bead Seat Bands STANDARD

FOR 5-PIECE RIMS/WHEELS

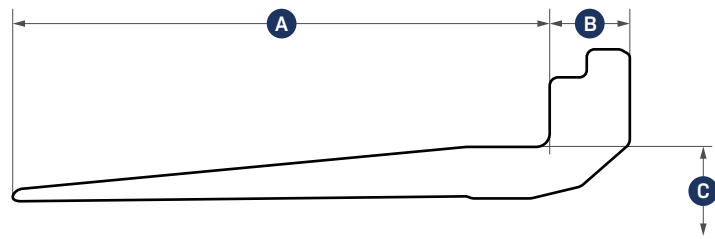

Rim Diameter	Dimensions			Driver Type	Weight	Part Number
	A	B	C			
IN (MM)	IN (MM)	IN (MM)	IN (MM)		LBS (KG)	
63	9.17 (232.9)	1.38 (35.1)	63 (1,600.2)	NONE	502 (227.7)	WBB056303

63" Bead Seat Bands HEAVY-DUTY

FOR 5-PIECE RIMS/WHEELS

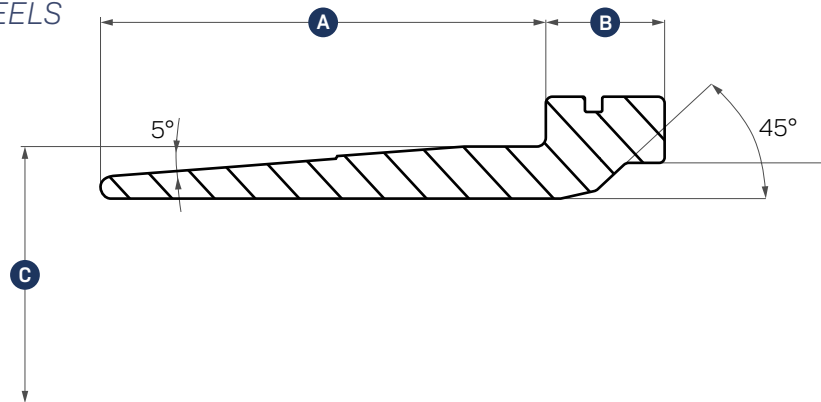

Rim Diameter	Dimensions			Driver Type	Weight	Part Number
	A	B	C			
IN (MM)	IN (MM)	IN (MM)	IN (MM)		LBS (KG)	
63	9.748 (247.6)	2.626 (66.7)	63 (1,600.2)	NONE	702 (318.4)	WBB056301

63" Bead Seat Bands **HEAVY-DUTY TAPERED**

FOR **5-PIECE** RIMS/WHEELS

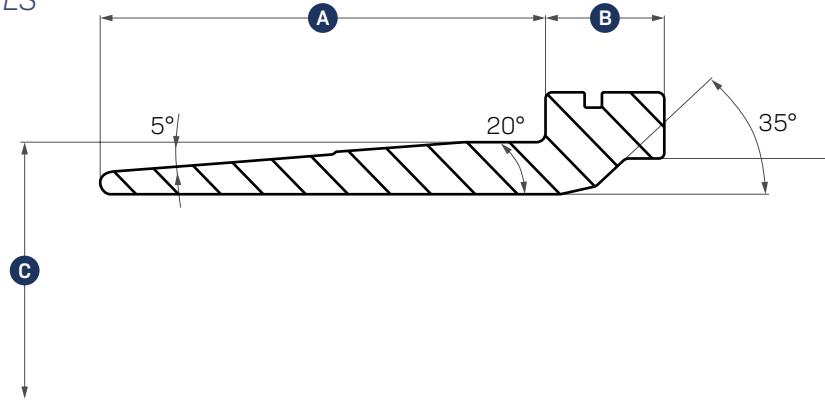

Rim Diameter	Dimensions			Driver Type	Weight	Part Number
	A	B	C			
IN (MM)	IN (MM)	IN (MM)	IN (MM)		LBS (KG)	
63	9.748 (247.6)	2.626 (66.7)	63 (1,600.2)	NONE	781 (354.3)	WBB056302

Driver Keys

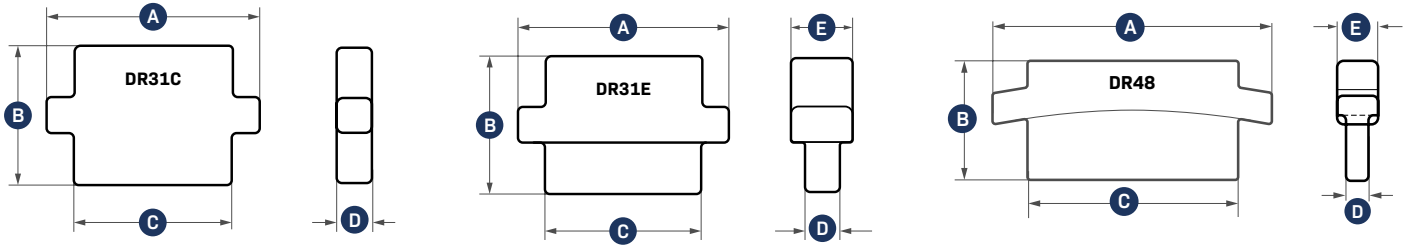





Dimensions					Weight	Part Number
A	B	C	D	E		
IN (MM)	IN (MM)	IN (MM)	IN (MM)	IN (MM)	LBS (KG)	
3.88 (98.6)	2.38 (60.5)	2.88 (73.2)	0.64 (16.3)	N/A	1.2 (0.5)	DR31C
3.88 (98.6)	2.38 (60.5)	2.88 (73.2)	0.64 (16.3)	1.14 (29.0)	1.9 (0.9)	DR31E
7.875 (200.0)	3.09 (78.5)	5.875 (149.2)	0.625 (15.9)	1.125 (28.6)	4 (1.8)	DR48

ADDITIONAL INFORMATION CAN BE PROVIDED REGARDING DRIVER POCKETS AND KEYS, AS WELL AS RIM LOCATORS. ASK YOUR SALESPERSON FOR A COPY OF OUR GUIDE.

Reference

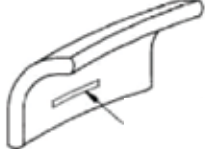
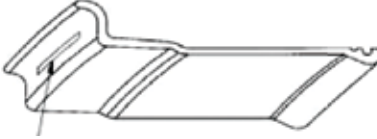
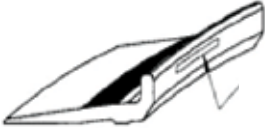
Stamped Part Number Locations

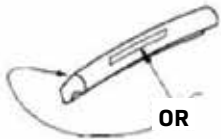
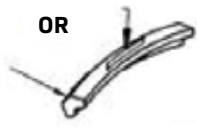
Multi-Piece Earthmover Stamp Location	Semi-Drop Center Rim Base Stamp Location
	
Multi-Piece Earthmover Flange Stamp Location	3-Piece Rim Base Stamp Location
	
Multi-Piece Earthmover Bead Seat Band Stamp Location	Side Flange Stamp Location
	
Multi-Piece Earthmover Lock Ring Stamp Location	Lock Ring Stamp Location
	



MAKE SURE PARTS ARE CORRECT SIZE AND TYPE BEFORE ASSEMBLING BY CHECKING THE PART NUMBER ON ALL OF THE RIM COMPONENTS.



Wheel Offset Examples

Inset Wheel

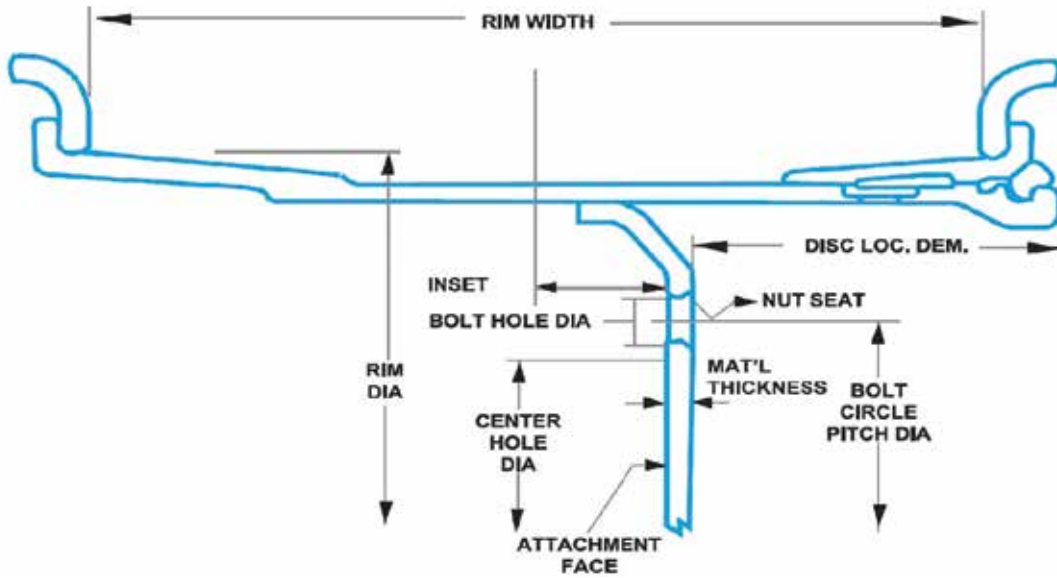

Zeroset Wheel

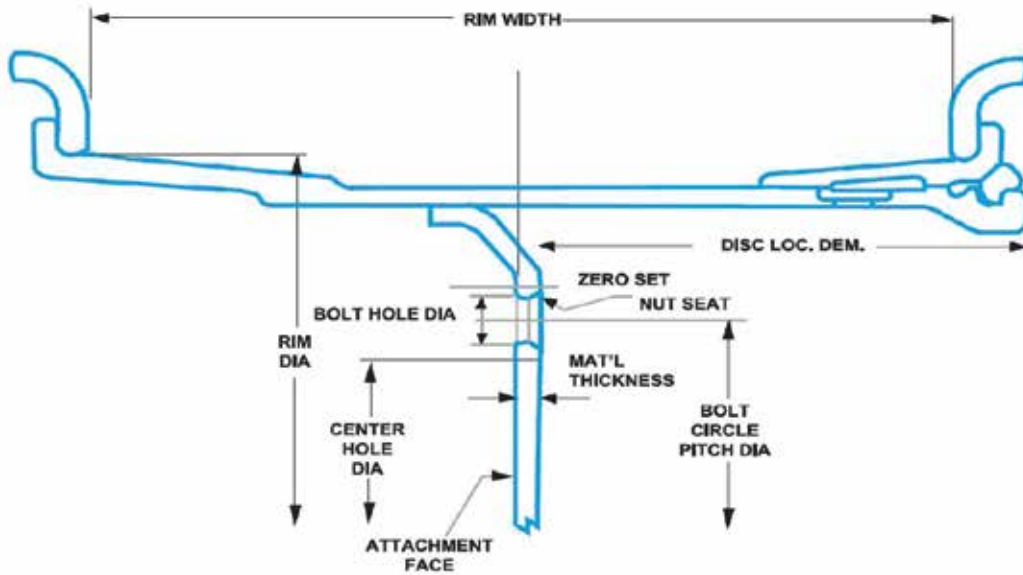

Outset Wheel

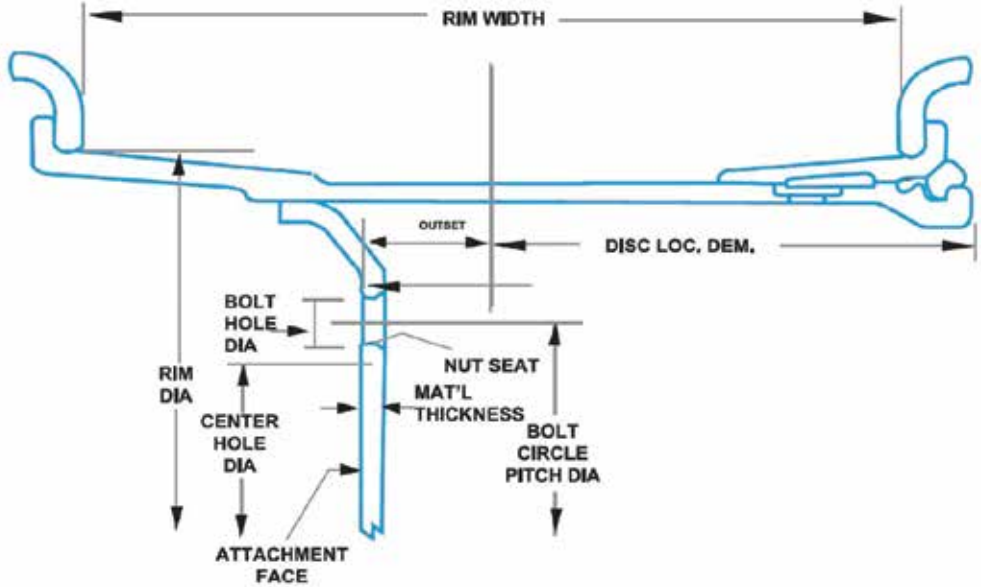

Wheel Disc Styles

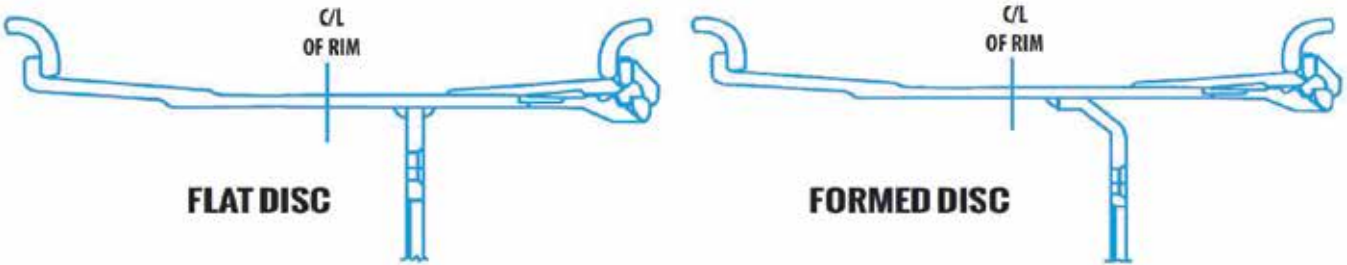

Wheel Disc Types

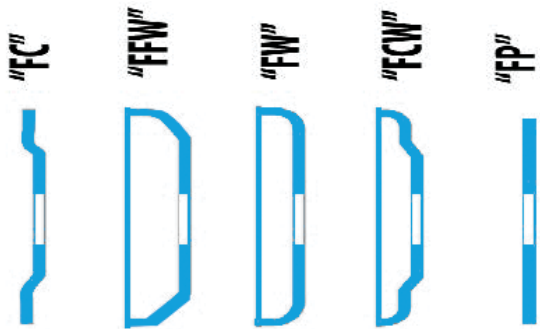

FORMED DISCS COME IN DIFFERENT PROFILES AND THICKNESSES.

Rim Terminology

- 1. Rim Base
- 2. Flanges (side-rings)
- 3. Bead Seat Band
- 4. Bead Seat Band 5° Taper
- 5. O-Ring Gasket
- 6. Lock Ring
- 7. Lock Ring Driver
- 8. Gutter Notch for Lock-Ring Driver
- 9. Gutter Section
- 10. Center Band Section
- 11. Back Section
- 12. Locator (*demountable rim only*)
- 13. Tubeless Valve Hole
- 14. Tube Type Valve Slot (*not shown*)
- 15. 28 Rim Mounting Surface
- 16. 5° Tire Mounting Surface
- 17. Lock Ring Groove
- 18. O-Ring Groove
- 19. Gutter Section Weld
- 20. Back Section Weld
- 21. Inverted Valve Hole
- 22. Standard Valve Hole
- 23. Outboard Driver Pocket (*bead seat band*)
- 24. Outboard Driver Pocket (*rim base*)
- 25. Locking Driver Key
- 26. Flange Height
- 27. Serrations or Knurling
- 28. Pry Bar Slot
- 29. Rim Base
- 30. Side Flange
- 31. Lock Ring
- 32. O-Ring Seal
- 33. 28° Mounting Surface
- 34. Lock Ring Groove
- 35. O-Ring Groove

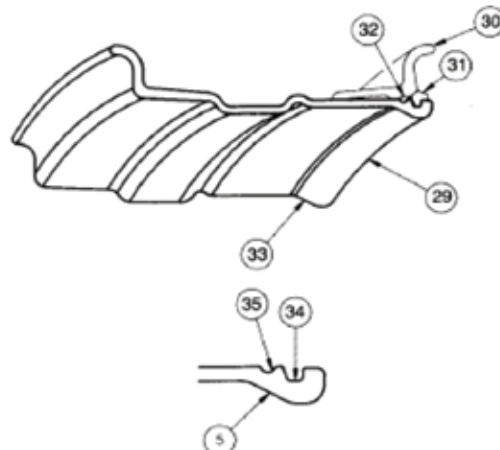
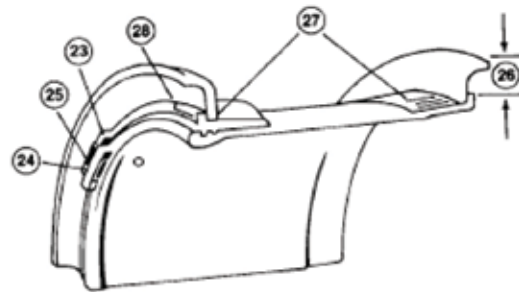
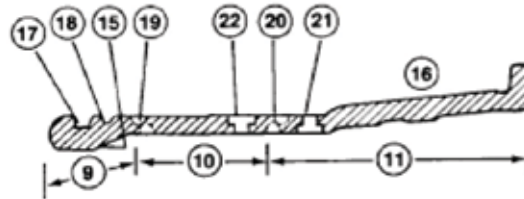
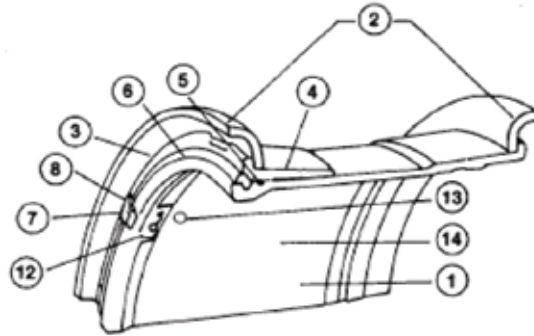

Underground Mining

UNDERGROUND MINING WHEELS

OTR's mining wheel lineup for underground haulers and loaders is available in 3- and 4-piece configurations. Manufactured by OTR, these steel wheels feature 100% seamless, hot-forged components with HSLA-grade steel for critical components. A Nut Guard option is available for select units for gutter and driver pocket protection, as well as driver locking systems for high-torque applications. Wheels are supplied to OEMs and the aftermarket with precise fitments for popular vehicles and machines used underground.



20x10 3-piece UGM HD wheel assembly manufactured in-house; 100% seamless, hot-forged components.



20x15 3-piece UGM HD wheel assembly manufactured in-house; 100% seamless, hot-forged components.



24x8.5 3-piece UGM HD wheel assembly with integrated NUT GUARD feature for gutter and driver pocket protection.



25x14 3-piece UGM HD wheel assembly manufactured in-house; 100% seamless, hot-forged components.



25x14 3 piece UGM HD wheel assembly with driver locking system for high-torque applications.

OTHER SIZES AVAILABLE.



Services

WHEEL INSPECTION AND RECERTIFICATION

OTR's after-sale support includes a proven wheel inspection and recertification process for vehicles used at mine sites. This capability is enhanced by OTR's experience in developing and supplying heavy-duty wheels to OEMs, resulting in a core competency that can be leveraged for dealers and end users alike. If wheels are determined to be defective, OTR will work with the OEM, dealer, or end user to specify and supply OEM-approved replacements. The process employed ensures safe demounting with documentation for future reference. Contact your OTR salesperson to discuss how to start this process.

- Verification of wheel condition; isolates defective wheels or wheels nearing end-of-life before there is a potential danger.
- Documentation of wheel duty cycle, application, visible wear, and hidden issues using a proprietary non-destructive testing (NDT) scoping technique to identify potential failures. The main use of the ultrasonic is at ports and some U.S. mines. Mainly Magnetic Particle, but NDT will cover both.
- Full report documenting findings for traceability purposes.
- Training for customer's sales staff and end users, including how to use go/no-go gauges.

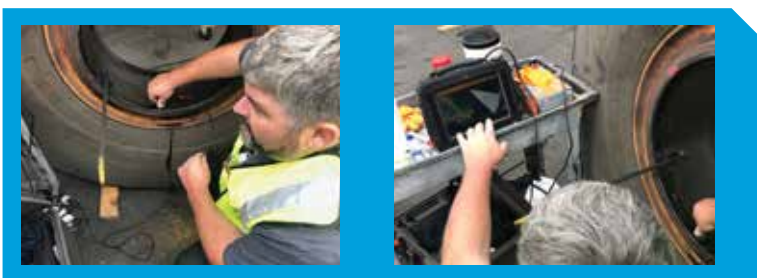

OTR can also provide custom-designed go/no-go gauges to verify wheel compliance (pictured left).

SUPPLY CHAIN PROTECTION ISO-9001

The Customs-Trade Partnership Against Terrorism (C-TPAT) was created by U.S. Customs and Border Protection (CBP) as a voluntary program for companies that are involved in the global supply chain.

As a C-TPAT partner, we do our part to alleviate supply chain disruption and reduce border delays.



FREQUENTLY ASKED QUESTIONS ABOUT C-TPAT CERTIFICATION:

→ **Why does this matter to me?**

Expedited port entry, more accurate delivery schedules, and protecting our borders. Being C-TPAT certified allows our shipping containers to bypass the security-related delays at the ports of entry. Our certification ensures that our supply chain is secure throughout; from the manufacturing facility, through the ports, and on to the final destination.

→ **How much time can be saved by being C-TPAT certified?**

There are many factors involved, but the government estimates that non-certified shipments are 3.5 times more likely to be delayed by security inspection. Also, should a C-TPAT certified shipment be randomly chosen for inspection, it is given priority status and is moved to the front of the existing queue for inspection.

→ **Is C-TPAT certified easy?**

Actually, it is a very comprehensive process that can take years to complete. There are a series of site visits throughout the supply chain, reference checks, paperwork, fees, and even a personal interview. C-TPAT certified companies must permanently adhere to strict policies in order to maintain certification.



ISO CERTIFICATION

The International Organization for Standardization (ISO) helps to set global standards of excellence for both quality and management systems. Certified companies must undergo rigorous inspections and evaluations to ensure that they adhere to the highest standards.

ISO BENEFITS:

- Consistent product quality.
- Standardized production and record keeping.
- Product dependability.
- Enhanced customer satisfaction.



CONTACT INFORMATION

OEM Inquiries: Contact your local OTR salesperson or email sales@otrwheel.com.

Aftermarket Inquiries: Contact your local OTR salesperson or call 800-833-6309 (east of the Mississippi River) or 888-455-4910 (west of the Mississippi).

Trans American Rubber Tubes, Flaps, or Accessories: Call 800-922-8823 for additional information.

WARRANTY INFORMATION

OTR provides limited warranty coverage for tires, wheels, tracks, and other items in the event of defects in workmanship. You may request a copy of our policy by emailing us at sales@otrwheel.com.

Note that OTR has designated select dealers and distributors to assist with warranty repairs. Contact OTR for more information.

CATALOG DISCLAIMER

Product specifications and information were correct as of the date of this catalog release, but are subject to change without notice or obligation. Every effort has been made to ensure the accuracy of this catalog. Consult with your salesperson if you wish to verify data is correct.

ISO 9001: 2015 CERTIFICATION

OTR facilities are ISO 9001: 2015 registered (except for new locations where certifications are in process). ISO ensures consistent product quality, standardization, documentation, and compliance with OEM requirements.

COMPLIANCE

Assemblies and components manufactured according to Tire & Rim Association (TRA) standards.

USA-ASTM Standard: A36/A1011M, A529, A572

DIN Standards: ST 37-2, ST42-2, ST52-3

China Standards: Q235, Q275, Q345

REACH COMPLIANCE

OTR's custom tires for OEMs can be designed with REACH compliance. Consult with your salesperson as needed.



Engineered Solutions

OTR's Commitment:

SOLUTIONS

OTR doesn't just sell tires and wheels, we diagnose problems and provide solutions.

VALUE

OTR optimizes ROI with high performance & value-added services to deliver results.

INNOVATION

OTR has a passion for innovating solutions that exceed customer expectations.

PARTNERSHIP

We're not just a vendor, we're a long-term partner who will support your business.

+1.800.833.6309

www.otrwheel.com

OTR is the operating unit of OTR International, Inc., comprising businesses located in the U.S., Canada, Europe, China, Thailand, and Sri Lanka. OTR is a partner company of Owner Resource Group (ORG), LLC.

© 2024 OTR International, Inc. All Rights Reserved. | C-US-V052424